

# INSTALLATION AND WIRING DIAGRAM

USA

## TECHNICAL

### DC TRANSFORMER for LEDRA™ TRACK

ART. NO. 70419 5V-5A

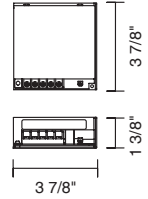

## IMPORTANT SAFETY INSTRUCTIONS



1. Read all instructions!
2. Turn off power prior to any work on the systems.
3. Only a qualified electrician should install this hard wired driver.
4. Only for installation in dry locations.
5. Total wattage of the system must never exceed the wattage supplied by the low voltage driver.
6. Input: 100-240VAC / 50-60Hz.
7. Warranty is void in case of unauthorized modifications and/ or improper use

## READ ALL OF THESE INSTALLATION INSTRUCTIONS BEFORE INSTALLING THE FIXTURE

### Content of Delivery:

DC TRANSFORMER for LEDRA TRACK- qty. (1)

#### FRONT VIEW

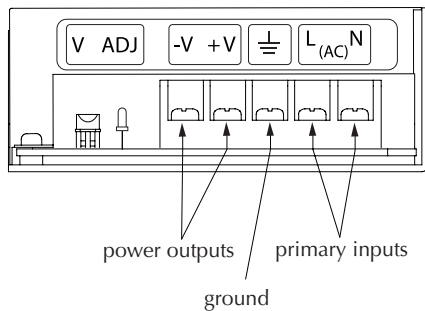

**Mounting:** To mount the driver, screws may be attached in any of the various mounting points (mounting screws not included).

**Grounding:** The driver must be grounded by connecting the ground wire to the driver terminal block, marked with the  $\perp$  symbol.

**Output Connections:** \*this driver is designed for use with the LEDRA TRACK only!  
 Connect the positive and negative power supply cable from the LEDRA TRACK to the the driver terminal blocks, marked -V and +V respectively. Tighten the screws firmly.

**Note:** black wire from the power feed goes to the negative terminal and the clear wire goes to the positive terminal.

**Input Connections:** Connect the line voltage wires to the line input and neutral connections marked L and N, on the driver terminal blocks. Tighten the screws firmly.

The system is now ready...you can turn on the lights!

