

# Boxie Large (Fluorescent Version)

700BXL\_-CF

1.3



## GENERAL PRODUCT INFORMATION:



This product can mount to either a 4" square electrical box with round plaster ring or an octagon electrical box.

This product is suitable for indoor dry locations only.



### CAUTION — RISK OF FIRE

This product requires installation by a qualified electrician. Before installing be sure to read all instructions and **TURN THE POWER TO THE ELECTRICAL BOX OFF.**

## Install the Fixture

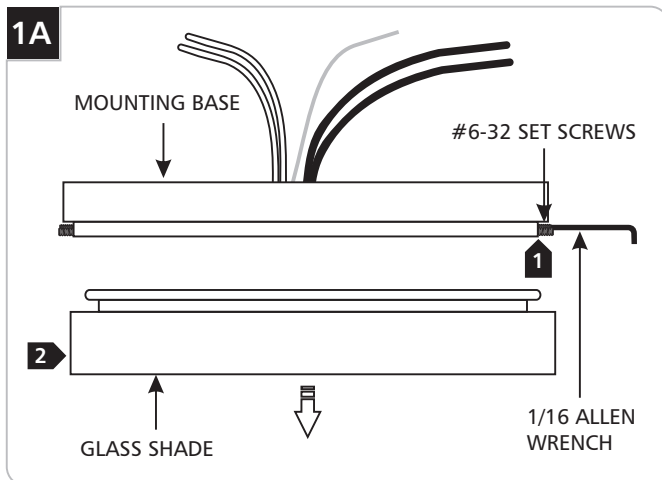

**1** While supporting the glass shade, loosen (**Do Not Remove**) the four #6-32 set screws on mounting plate with the 1/16 Allen wrench.

**2** Carefully remove the glass out of the mounting base.

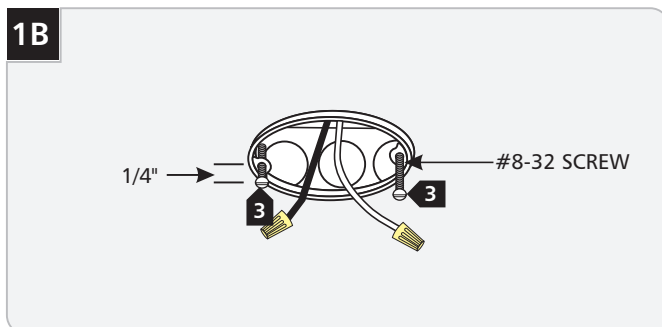

**3** Thread (**NOT COMPLETELY**) the two #8-32 screws into the electrical box holes leaving 1/4" of them exposed.

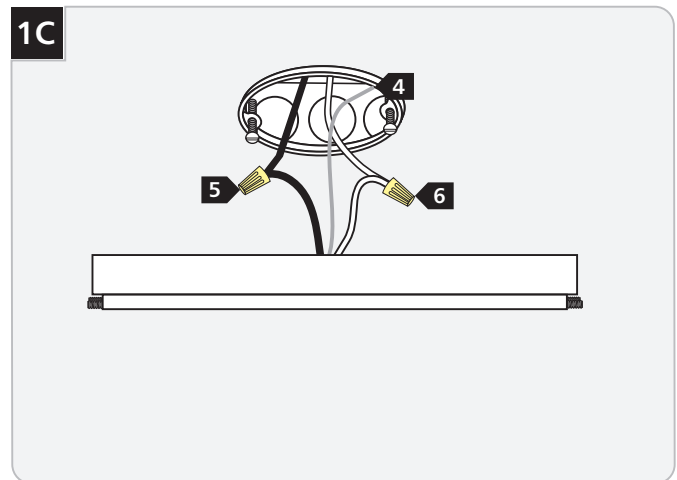

**4** In accordance with local electrical codes, ground the fixture bare wire.

**5** Connect the fixture black wire to the power line hot wire with a wire nut.

**6** Connect the fixture white wire to the power line neutral wire with a wire nut.

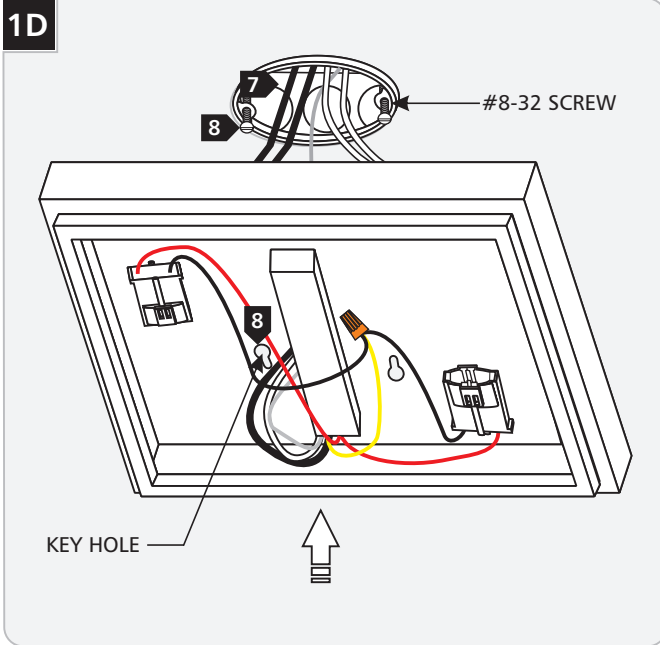

- 7** Place all wires and wire nut connections into the electrical box.
- 8** Using the key holes, hook the mounting base onto the #8-32 screws. Tighten the #8-32 screws.

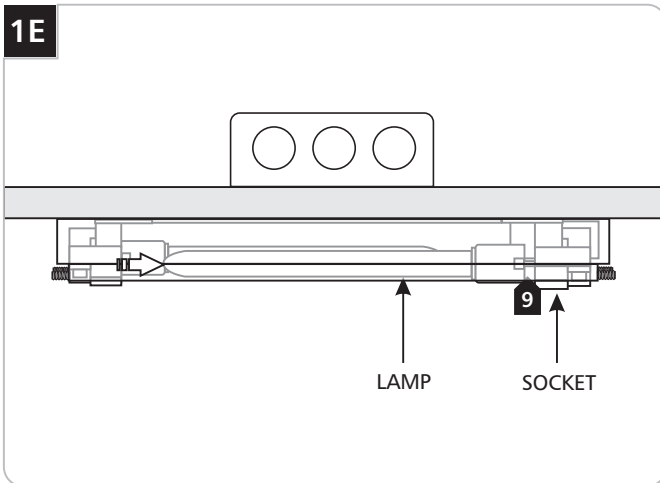

**CAUTION:** To reduce the risk of a burn or electric shock during relamping, disconnect the power to the fixture.

**NOTE:** Use only your fingers to install the lamps.

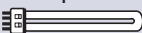
**Max** 13 Watt 2GX7 Base Twin Tube Compact Fluorescent Lamp for each socket. 

- 9** Push the lamp completely into the socket holes.

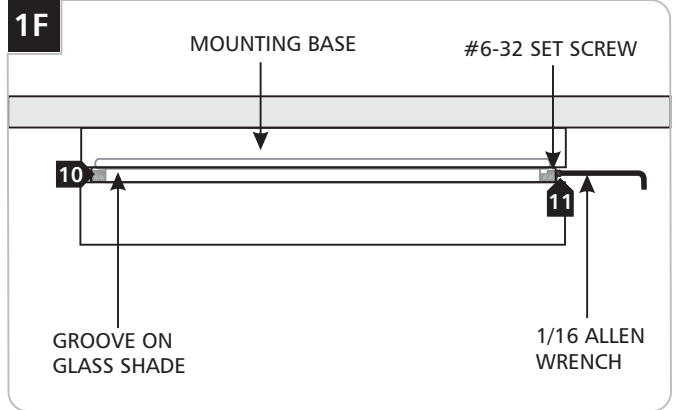

- 10** Align and place the glass shade into the mounting base so that the grooved section of the glass shade is completely in the mounting base.
- 11** Hold the glass shade in place and tighten all four #6-32 set screws with the 1/16 Allen wrench to lock the glass shade in place.

**NOTE:** To replace the lamp, follow steps 1 & 2. Pull the old lamp out and follow steps 9 through 11.

**SAVE THESE INSTRUCTIONS!**

 **TECH LIGHTING®**

7400 Linder Ave, Skokie, IL 60077  
847.410.4400

[www.techlighting.com](http://www.techlighting.com)

© 2008 Tech Lighting, L.L.C. All rights reserved. The "Tech Lighting" graphic is a registered trademark of Tech Lighting, L.L.C. Tech Lighting reserves the right to change specifications for product improvements without notification.  
A Generation Brands Company