











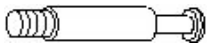

STYLE NO. **KA9466 – DISTRESSED BLACK**
KA9467 – WHITE
KA9468 – DISTRESSED RED

SOUTHERN ENTERPRISES INC.

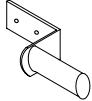

RELAX...If you can follow a few easy, step-by-step directions in order .YOU CAN ASSEMBLE THIS ITEM.

TRASH BIN STORAGE TABLE WITH CUTTING BOARD

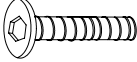
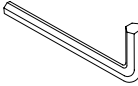
PLEASE FIND HARDWARE IN RED POLYBAG BEFORE DISCARDING PACKING MATERIAL.

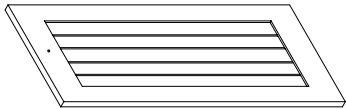
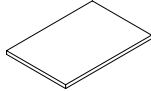
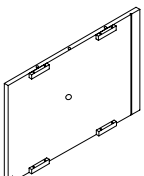
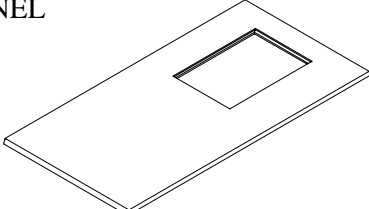
HARDWARE LIST			
(1) WOOD DOWEL	32PCS	(7) WOOD KNOB	1PC
			
(2) CAM-BOLT	14PCS	(8) SMALL MACHINE SCREW	1PC
		 Ø5/32"X19mm	
(3) CAM-LOCK	14PCS	(9) LONG FLAT HEAD WOOD SCREW	20PCS
		 Ø3X15mm	
(4) COVER	14PCS	(10) SHORT FLAT HEAD WOOD SCREW	4PCS
		 Ø3X10mm	
(5) METAL HINGE	2PCS	(11) PAN HEAD WOOD SCREW	27PCS
		 Ø3X10mm	
(6) METAL STOPPER	2PCS	(12) LARGE MACHINE SCREW	12PCS
		 Ø1/4"X16mm	
		(13) WRENCH	1PC
			

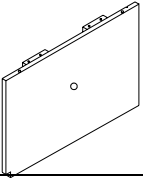
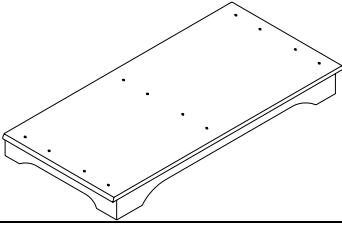
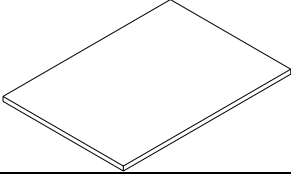
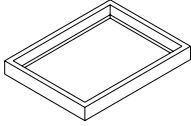
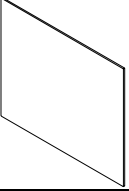
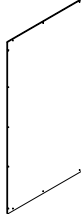
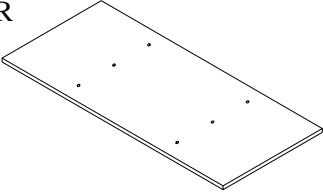
PARTS LIST			
(A) TRASH BIN FRONT PANEL	1PC	(I) CUTTING BOARD	1PC
			
(B) TRASH BIN LEFT PANEL	1PC	(J) TOP PANEL	1PC
			

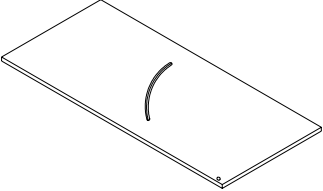
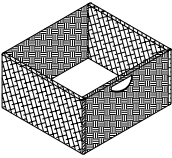
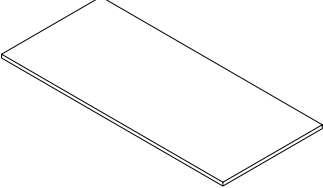
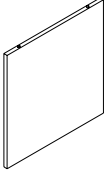
(C) TRASH BIN RIGHT PANEL 	1PC	(K) BASE 	1PC
(D) TRASH BIN BACK PANEL 	1PC	(L) WOOD FRAME 	1PC
(E) TRASH BIN BOTTOM PANEL 	1PC	(M) BACK PANEL 	2PCS
(F) DIVIDER 	1PC	(N) RATTAN BASKET BOTTOM 	3PCS
(G) LEFT SIDE PANEL 	1PC	(O) RATTAN BASKET FRAME 	3PCS
(H) RIGHT SIDE PANEL 	1PC	(P) SHELF 	2PCS

ASSEMBLY INSTRUCTION

1. SELECT A SMOOTH, SOFT SURFACE TO PREVENT SCRATCHING FINISH.
2. YOU MAY NEED A PHILLIP SCREWDRIVER.
3. **INSERT LARGE MACHINE SCREWS (12) THROUGH THE HOLES ON SIDE OF RATTAN BASKET FRAME (O) AND TIGHTEN INTO CORRESPONDING HOLES ON RATTAN BASKET BOTTOM (N) BY USING WRENCH (13).** ASSEMBLE THE OTHER TWO RATTAN BASKETS IN SAME MANNER. AS FIGURE 1 SHOWN.
4. INSERT METAL STOPPERS (6) INTO CORRESPONDING HOLES ON INSIDE OF TRASH BIN LEFT AND RIGHT PANELS (B, C). INSERT SHORT FLAT HEAD WOOD SCREWS (10) THROUGH ENDS OF METAL STOPPERS (6) AND TIGHTEN INTO PREDRILLED HOLES ON INSIDE OF TRASH BIN LEFT AND RIGHT PANELS (B, C). INSERT WOOD DOWELS (1) INTO PREDRILLED HOLES ON TRASH BIN FRONT PANEL (A) AND FIT INTO THE CORRESPONDING HOLES ON EDGES OF TRASH BIN LEFT AND RIGHT PANELS (B, C). INSERT LONG FLAT HEAD WOOD SCREWS (9) THROUGH PREDRILLED HOLES ON WOOD BARS ON INSIDE OF TRASH BIN LEFT AND RIGHT PANELS (B, C) AND TIGHTEN

INTO PREDRILLED HOLES ON TRASH BIN FRONT PANEL (A). SLIDE TRASH BIN BOTTOM PANEL (E) INTO GROOVES ON INSIDE OF TRASH BIN LEFT AND RIGHT PANELS (B, C) AND ATTACH TO TRASH BIN FRONT PANEL (A). PERFORM THE SAME WAY TO ASSEMBLE TRASH BIN BACK PANEL (D). AS FIGURE 2 AND INSET SHOWN.

5. INSERT **SMALL MACHINE SCREW (8)** THROUGH BACK OF TRASH BIN FRONT PANEL (A) AND TIGHTEN INTO WOOD KNOB (7). ATTACH METAL HINGES (5) TO THE CORNERS OF TRASH BIN FRONT PANEL (A), INSERT LONG FLAT HEAD WOOD SCREWS (9) THROUGH PREDRILLED HOLES ON METAL HINGES (5) AND TIGHTEN INTO PREDRILLED HOLES ON BOTTOM EDGE OF TRASH BIN FRONT PANEL (A). AS FIGURE 2 AND INSET SHOWN.

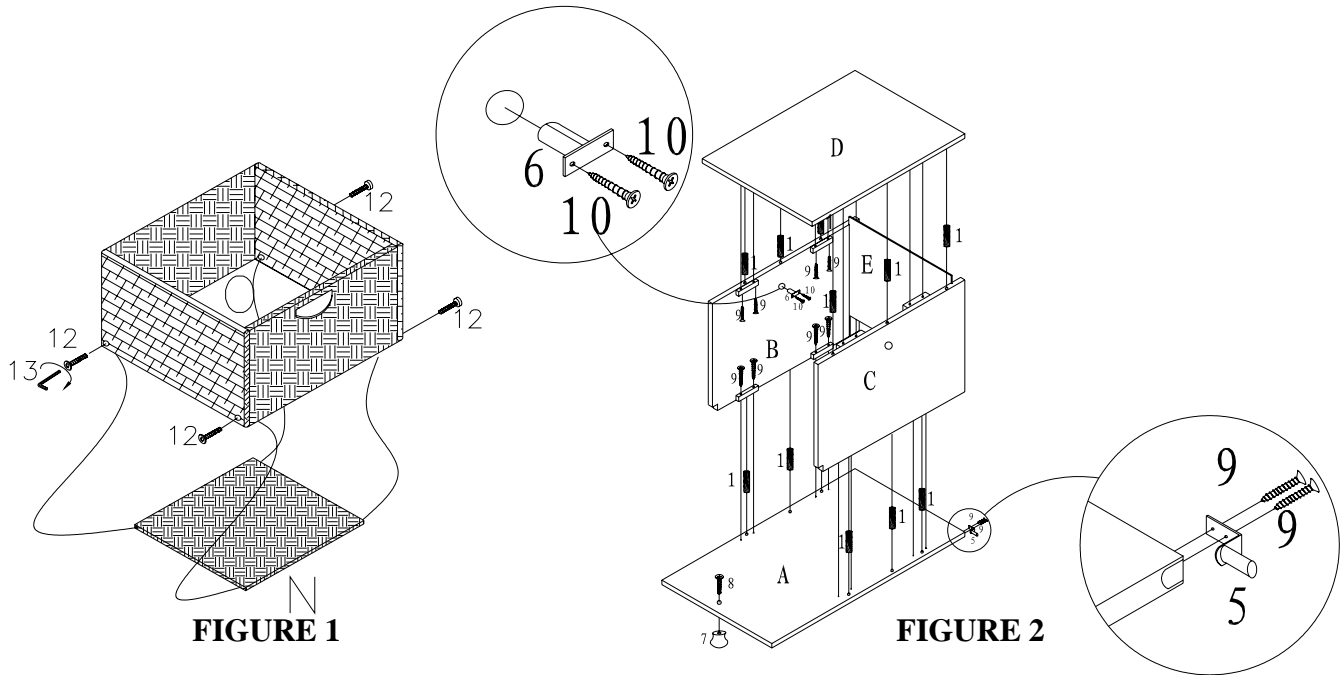

6. INSERT WOOD DOWELS (1) AND CAM-BOLTS (2) INTO PREDRILLED HOLES ON INSIDE OF DIVIDER AND RIGHT SIDE PANEL (F, H) AND FIT INTO CORRESPONDING HOLES ON ENDS OF SHELVES (P). INSERT CAM-LOCKS (3) INTO BIG HOLES ON UNDERSIDE OF SHELVES (P) WITH SLOT FOR SCREWDRIVER FACING OUTWARD. ROTATE CAM-LOCKS (3) CLOCKWISE TO SECURE CAM-BOLTS (2). PUSH COVERS (4) INTO CAM-LOCKS (3). AS FIGURE 3 SHOWN.
7. INSERT METAL HINGES AND STOPPERS (5, 6) EXTENDING FROM ASSEMBLED TRASH BIN INTO CORRESPONDING HOLES AND GROOVES ON LEFT SIDE PANEL AND DIVIDER (G, F). AS FIGURE 4 SHOWN.

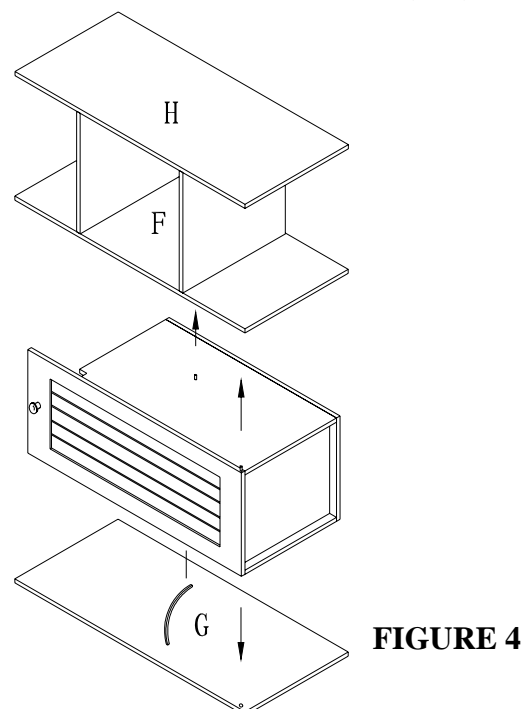
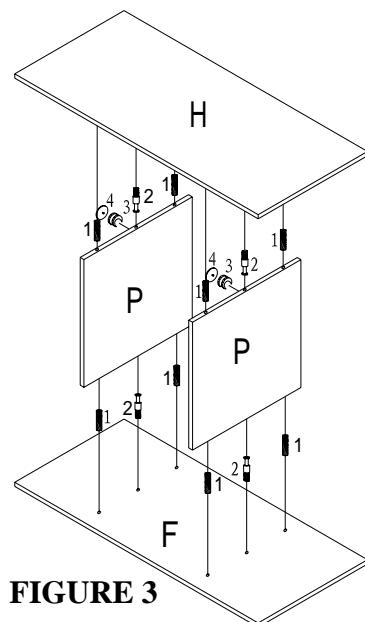

8. INSERT WOOD DOWELS (1) AND CAM-BOLTS (2) INTO PREDRILLED HOLES ON UPSIDE OF BASE (K), WITH AN ASSISTANT, INSERT WOOD DOWELS (1) AND CAM-BOLTS (2) EXTENDING FROM BASE (K) INTO CORRESPONDING HOLES ON BOTTOM EDGES OF PARTS (G, F, H). INSERT CAM-LOCKS (3) INTO BIG HOLES ON INSIDE OF PARTS (G, F, H) WITH SLOT FOR SCREWDRIVER FACING OUTWARD. ROTATE CAM-LOCKS (3) CLOCKWISE TO SECURE CAM-BOLTS (2). PUSH COVERS (4) INTO CAM-LOCKS (3). AS FIGURE 5 SHOWN.
9. INSERT WOOD DOWELS (1) AND CAM-BOLTS (2) INTO PREDRILLED HOLES ON UNDERSIDE OF TOP PANEL (J) AND FIT INTO CORRESPONDING HOLES ON TOP EDGES OF PARTS (G, F, H). INSERT CAM-LOCKS (3) INTO BIG HOLES ON INSIDE OF PARTS (G, F, H) WITH SLOT FOR SCREWDRIVER FACING OUTWARD. ROTATE CAM-LOCKS (3) CLOCKWISE TO SECURE CAM-BOLTS (2). PUSH COVERS (4) INTO CAM-LOCKS (3). AND FIT THE CUTTING BOARD (I) INTO THE TOP PANEL (J). AS FIGURE 5 SHOWN.

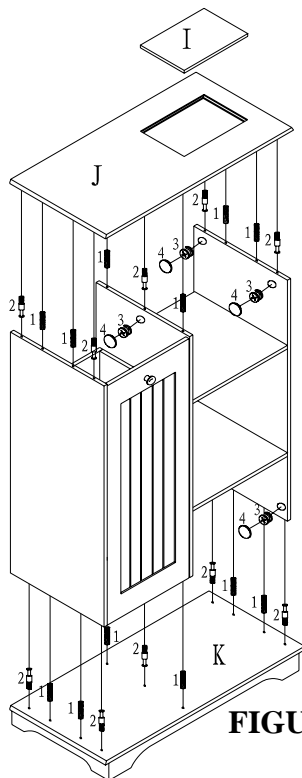

FIGURE 5

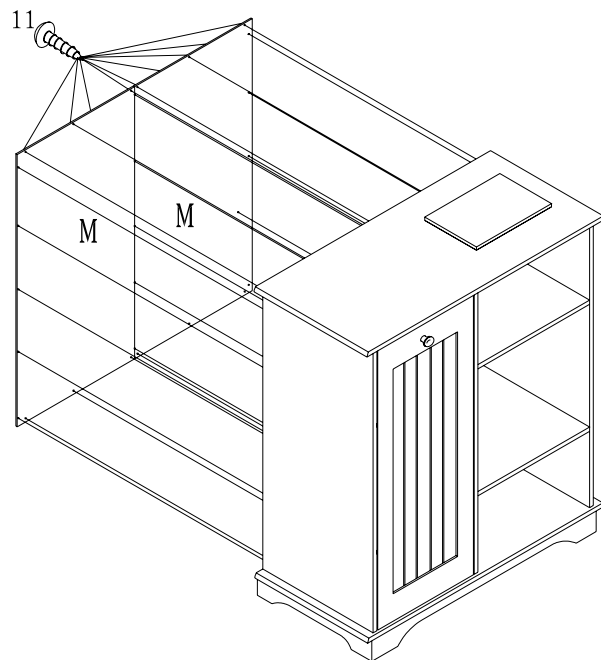

FIGURE 6

10. ATTACH BACK PANELS (M) INTO SLOT ON REAR EDGES OF PARTS (F, G, H, J, K). TIGHTEN PAN HEAD WOOD SCREWS (11) THROUGH PREDRILLED HOLES ON BACK PANELS (M) INTO PREDRILLED HOLES ON REAR EDGES OF PARTS (F, G, H, J, K). AS FIGURE 6 SHOWN.
11. OPEN THE ASSEMBLED TRASH BIN, PLACE WOOD FRAME (L) ON THE TOP OF THRASH BIN. AND PLACE THE RATTAN BASKETS INTO THE UNIT. FIGURE 7 SHOWN.

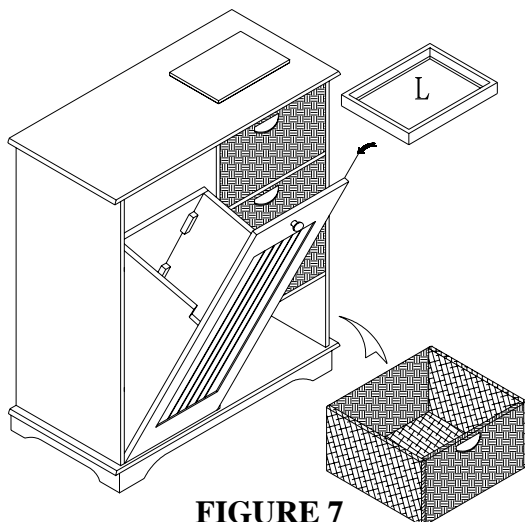
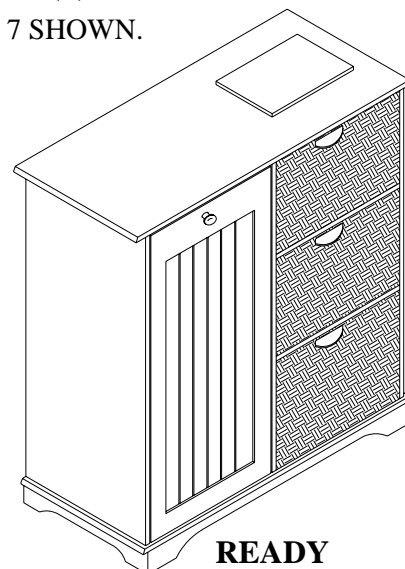

FIGURE 7



READY

YOUR NEW TRASH BIN STORAGE TABLE W/CUTTING BOARD IS FINISHED AND READY TO USE.

Please count, identify and compare parts and hardware list to be sure all parts are present. It may help to divide parts and label them to correspond with part list. Extra hardware may be included. If any items are missing, please contact our parts/service department at (800) 633-5096 or in Dallas (972) 869-0111/ 9am – 4pm Mon-Fri Central time. Missing or damaged hardware and/ or parts will be replaced free of charge. WE DO NOT SELL PARTS. WE DO NOT RECOMMEND MODIFYING PRODUCT(S) AND WE ARE NOT RESPONSIBLE FOR ANY DAMAGES DUE TO PRODUCT MODIFICATION(S). If this product has not been purchased from our retail affiliates (within 9 months), we are under no obligation to provide parts or replacement merchandise. Parts will not be available for items arriving fully assembled.

"We will ship parts if available" "This is not a warranty"

PARTS REPLACEMENT FORM			
STYLE NO: KA9466/KA9467/KA9468			
Customer Name	PARTS LETTER	PART DESCRIPTION	QUANTITY NEEDED
Street, City, State, Zip			
Phone#			
		_____ _____ Please indicate where you purchased this item. Store/website/catalog _____ / _____ / _____ Please indicate color/size/style number _____ / _____ / _____	
SOUTHERN ENTERPRISES INC. P.O. Box 59996 Dallas, Texas 75229			