

54" x 32" x 23"

OAHU (J-29)

Classic SERIES



THE COMFORTABLE OAHU WITH ARMRESTS AND A REMARKABLY LARGE BATHING AREA IS THE PERFECT ESCAPE FOR LIMITED SPACE APPLICATIONS.

FEATURES:

- 5 flow-adjustable and directional jets including:
 - 1 back jet
 - 2 hip jets
 - 2 foot jets
- 1.5 B.H.P. pump - 7.5 Amps
- High gloss / high impact acrylic in standard colors
- Totally insulated with polyurethane foam
- Silent passive warm air induction system
- Drain back technology for sanitary bathing
- 10-year limited factory warranty
- Anti-microbial flex piping
- Lumbar support for comfort
- Extra thick glassing
- Pre-leveled lip
- Slip resistant bottom
- Energy efficient
- Noise absorbtion

OPERATING GALLONS (APPROX.):

- Regular Usage - 30 gal.

OPTIONS AVAILABLE:

- Air Option
- Mood or LED lights
- Tri-ssage control for distinct pump flow rates
- Bath waste & overflows
- Decorator and designer colors
- Contoured neck support pillow
- Jetted neck pillow
- Aromatherapy
- 6" acrylic grab bars
- Extra jets

COLORS AVAILABLE:

- White • Biscuit • Bone (Standard)
- Sandbar • Mexican Sand
- Black • Ice Grey

TRIM KIT FINISHES AVAILABLE:

- Polished Brass
- Polished Chrome
- Oil Rubbed Bronze
- Satin Nickel



STAY HOT GUARANTEE

Jetta guarantees that the water temperature in our insulated whirlpool and soaker baths will stay within 2 degrees of its original temperature after 30 minutes of use. Our fully insulated whirlpool and soaker baths with low density foam insulation and passive warm air induction systems help keep you warmer, longer.



TO ORDER OR FOR MORE INFORMATION, CALL 1-800-288-7771 FOR THE AUTHORIZED REPRESENTATIVE IN YOUR AREA

OAHU (J-29)

54" x 32" x 23"

JETTA CORPORATION TECHNICAL SPECIFICATIONS

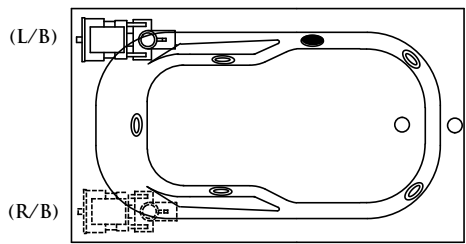
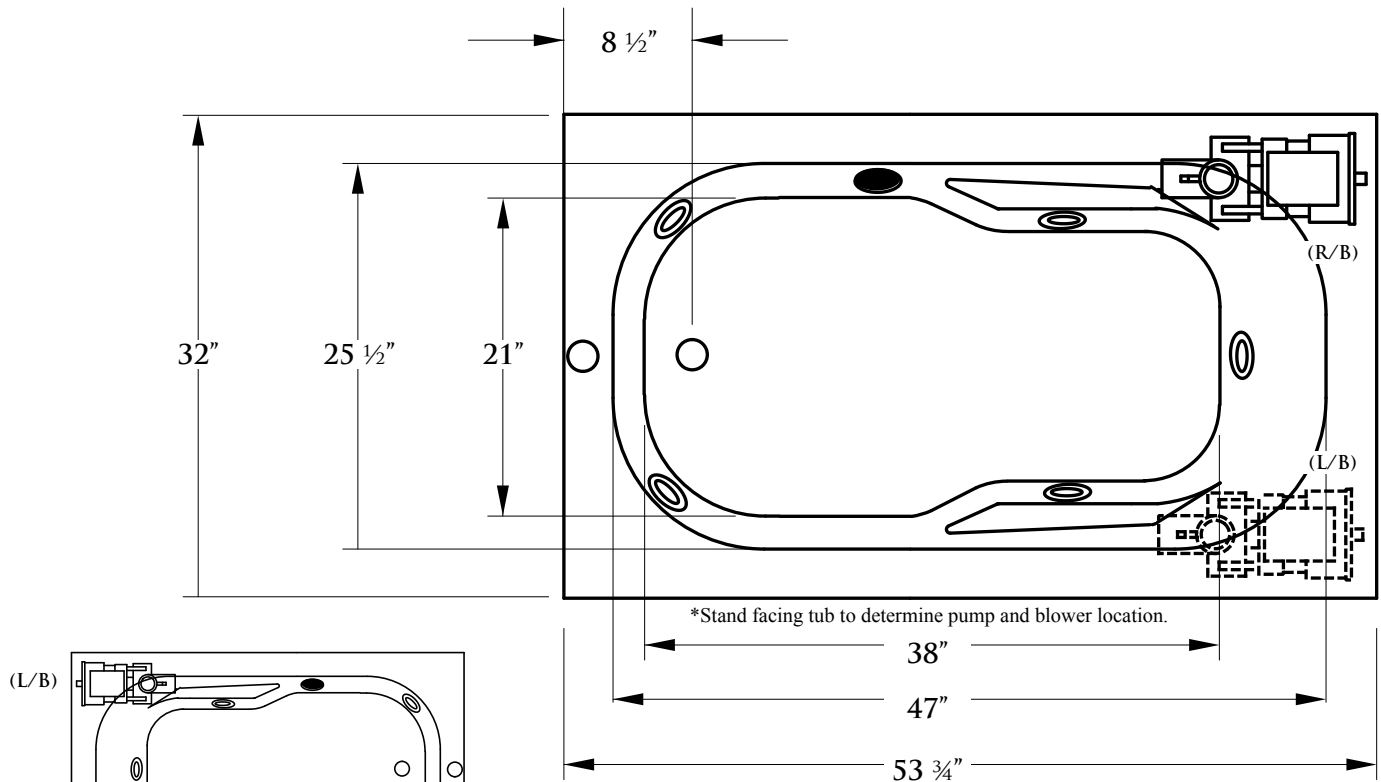

*Stand facing tub to determine pump and blower location.

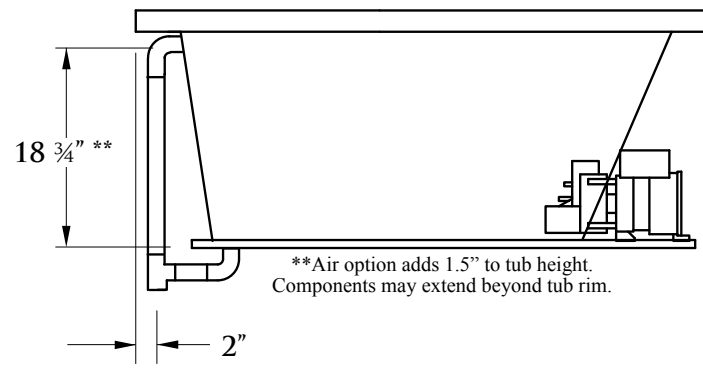

**Air option adds 1.5" to tub height. Components may extend beyond tub rim.

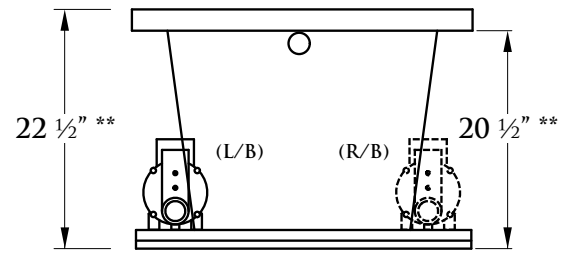

**Air option adds 1.5" to tub height. Components may extend beyond tub rim.

ELECTRICAL SPECIFICATIONS:
 Required Electrical Service 110/115 Volts
 Standard Whirlpool 20 amp GFI
 Air Option 20 amp GFI
 Each pump and blower must be protected by a dedicated GFI breaker (refer to local codes).

CODES/STANDARDS APPLICABLE:
 Specified model meets or exceeds the requirements for the following standards: UL Listed, ANSI, ASME, IAPMO.

SUGGESTED PUMP & BLOWER ACCESS PANEL:
 20" x 12" - Actual recommended size may vary depending on distance of access to pump & blower location.

CUT OUT DIMENSION:
 Subtract 2" from outside edge.

SHIPPING WEIGHT: 220 lbs.



*L/B, R/B pump position determines suction location. Separate location required for air blower.

INSTALLATION: Measure tub before building tub deck. Add 1" to 3" of evenly distributed bedding compound under the base of the tub to provide maximum support. Tub should not be supported by rim in any way and should be level when installed. Jetta recommends using a quick setting concrete mix. Plastic sheeting should be laid between bedding and bath during installation. Drawing shows manufacturer's standard pump location. Optional locations available at an additional cost, depending on feasibility. Contact Jetta for details. Dimensional variance on drawings may be +/- 1/4 inch and are subject to change without notice.

