



Project: _____

Fixture Type: _____

Location: _____

Contact/Phone: _____

8" SQUARE TC HOUSING

INCANDESCENT LAMPS

TC6

PRODUCT DESCRIPTION

TC Housing designed for use in non-insulated areas • If installed where insulation is present, the insulation must be pulled back 3" from all sides of the TC housing.

PRODUCT SPECIFICATIONS

Lamp One 100W A19 lamp.

Socket Medium base porcelain with nickel-plated copper screw shell.

Trims Trim selection shown on reverse.

Labels UL listed for through-branch wiring, damp locations and IP

- Product thermally protected against improper use of insulation
- Union made AFL-CIO • UL Listed/CSA certified.

Testing All reports are based on published industry procedures; field performance may differ from laboratory performance.

Product specifications subject to change without notice.

INSTALLATION

Real Nail 3 Bar Hangers Telescoping, patent-pending Real Nail 3 system permits quick placement of housing anywhere within 24" O.C. joists or suspended ceilings • Integral T-bar notch and clip secures housing in suspended ceiling grid – no accessory clips required • 24" expansion stop allows quick placement of fixture in standard grid spacing • Bars scored in two locations for fast, clean breaking, allowing housing installation in tight applications • Bars captive to mounting frame • Edge-mounted for extra strength • Captive bugle-headed ring shank nail for quick one-step installation and easy removal with claw hammer for fixture relocation • Quick-Loc slot and oversized locking set screw lock fixture in position • Bar hanger foot contoured to align to bottom of construction joist • Alternate mounting holes included.

Junction Box Pre-wired junction box provided with (5) ½" and (1) ¾" knockouts, (4) Romex connectors and ground wire, UL listed/CSA certified for through-branch wiring, maximum 8 No. 12 AWG 90° C branch circuit conductors (4 in, 4 out) • Junction box provided with removable access plates • Knockouts equipped with pryout slots.

Mounting Frame 22-gauge die-formed galvanized steel mounting frame • 13½" L x 9¾" W, (excluding bar hangers) • Rough-in section (junction box, mounting frame, housing and bar hangers) fully assembled for ease of installation.

Housing TC housing, 22-gauge white painted steel • Housing is vertically adjustable to accommodate up to a 1" ceiling thickness.

DIMENSIONS

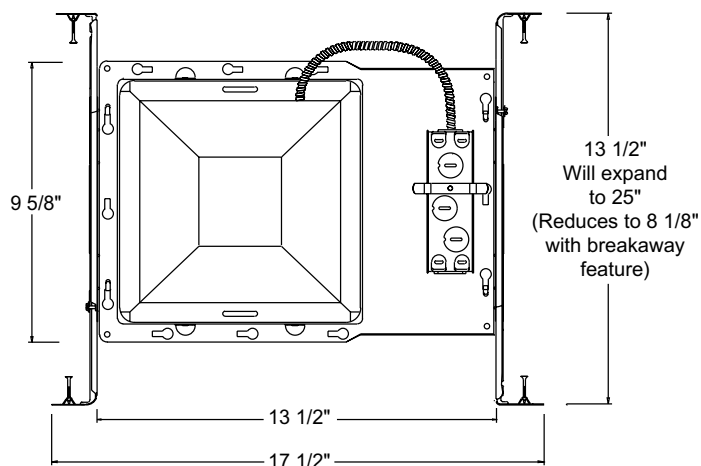
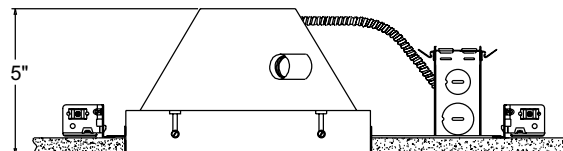

8 5/8" SQ. CEILING CUTOUT

PRODUCT CODES

Catalog Number	Input Voltage	Lamp Rating (max.)
TC6	120V	100W A19

8" SQUARE TC HOUSING

INCANDESCENT LAMPS

TC6

TRIMS/LAMPS



Cat. No.	Description	Lamp Rating
60-WH	Crystal Diffuser	100W A19

Trim Size: 9 $\frac{1}{8}$ " SQ.
Trim Finish: WH - White.



1300 S. Wolf Road • P.O. Box 5065 • Des Plaines, IL 60017-5065 • Phone (847) 827-9880 • Fax (847) 827-2925
220 Chrysler Drive • Brampton, Ontario • Canada L6S 6B6 • Phone (905) 792-7335 • Fax (905) 792-0064
Visit us at www.junolightinggroup.com

Printed in U.S.A. ©2005 Juno Lighting, Inc.