



WP2CH100QT



JOB NAME: _____
 DATE: _____
 TYPE: _____

DESCRIPTION

Wallpack with cutoff glare shield. All aluminum precision die cast construction with tempered glass lens. 30° cutoff strip included. Lamp supplied.

SPECIFICATIONS

Cutoff Lens:

Tempered glass.

Finish:

Chip and fade resistant polyester powder coating.

Housing:

Die cast aluminum, 1/2" NPS tapped holes top, both sides and back for conduit or photocontrol. Hinged refractor frame. Continuous silicone rubber gasket.

Reflector:

Specular anodized aluminum, removable for installation. Symmetrical light pattern maximizes distance between fixtures.

Refractor:

Prismatic optics designed to minimize glare and throw light down and out. Heat resistant borosilicate glass.

UL Listing:

Suitable for wet locations. HID fixtures can be wired with 90° C supply wiring if supply wires are routed 3" away from ballast.

EISA 2007 Compliant

This product complies with the new law for metal halide ballast efficiency. This law goes into effect January 1st, 2008

Patents:

RAB sensor and fixture designs are protected under U.S. and International Intellectual Property laws

Quad Tap:

Fixture works with 120, 208, 240 and 277 Volts

Color:

Bronze

Weight:

14.73

DIMENSIONS

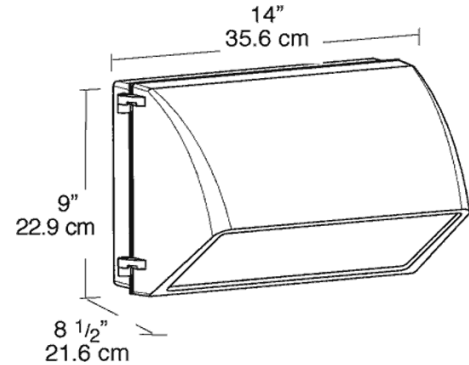

PHOTOMETRIC

150w HPS @10' Mounting Height

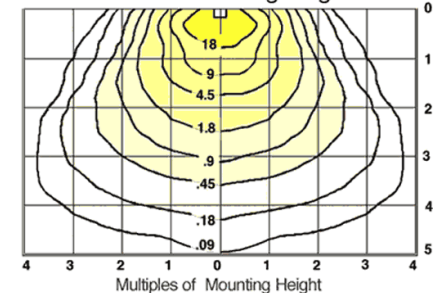

Mounting Height	Multiplier	Watts	Multiplier	HPS	MH	CFL
8'	1.6	175	1.1	1.0		
10'	1.0	150	.6	.6		
12'	.7	100	.4	.4		
16'	.4	70				
20'	.25	42				.2

ORDERING INFORMATION

Metal Halide	Total Watts	Lamp Type	Lamp Base	Ballast	Starting Amps/ Operating Amps	Input Watts	LAMP ANSI	Initial Lumens	Lamp Hours
					120V 208V 240V 277V				
Lamp supplied with fixture	100	ED17	Medium	HX-HPF QT	1.2/1.2 .7/.7 .7/.8 .6/.5	129	M90	9000	15000

Factory Installed Options
 Add suffix to Catalog Number

Tamperproof screws (/TP)
 Swivel Photocontrol (/PCS)
 Single fusing for 120 and 277 volt (/F)

Double fusing for 208 and 240 volt (/FF)
 Button Photocontrol for 208 - 277 volt (/PC2)
 Button Photocontrol (/PC)

Note: Specifications may change without notice