

AVAILABLE PART IS:
30130SH (SHADE)

SECTION "A-A"

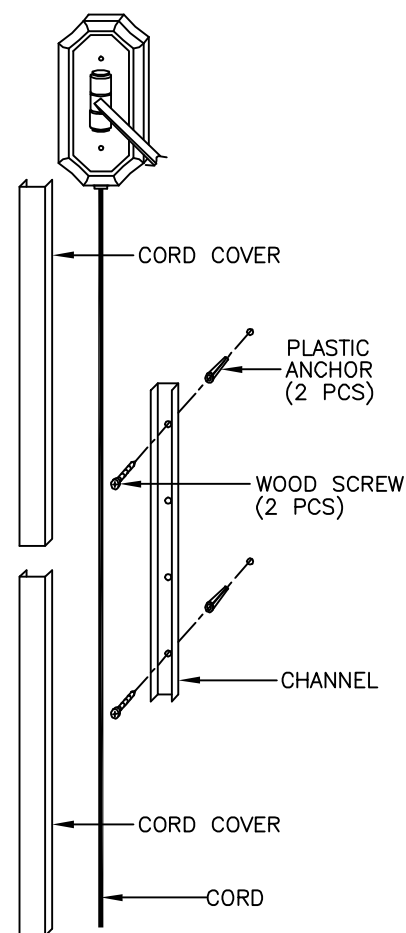

CORD COVER ASSEMBLY

PRODUCT SPECIFICATIONS

OVERALL ASSEMBLED DIMENSIONS:

HEIGHT: 39.4 CM (15-1/2"), WIDTH: 38.7 CM (15-1/4"), EXTENSION: 63.5 CM (25").

1 LIGHT: UL LISTED, 150 WATT, MEDIUM BASE E-26 ALUMINIUM SOCKET WITH A 3-WAY ROTARY SWITCH. THE SPIDER, HARP AND SOCKET ARE PB FINISH.

CORD: UL LISTED, 183 CM LENGTH, 18 AWG., 3 CONDUCTORS, TYPE SVT CORD, 105°C., SILVER/CLEAR COLOR, COMES WITH MATCHING CORD COVER. WIRES MUST BE LEAD FREE.

BACKPLATE: PLATED STEEL, 10.5 CM (4-1/8") WIDTH x 21 CM (8-1/4") LENGTH x 1.9 CM (3/4") HEIGHT.

ARM ASSEMBLY: PLATED STEEL, (2) ARMS, 12 MM (1/2") SQ. TUBING, SHAPED AS SHOWN.

SHADE: WHITE FABRIC SHADE, 12.6 CM (5") DIA. TOP x 30.5 CM (12") DIA. BOTTOM x 22.8 CM (9") SLANT HEIGHT.

LABEL: UL AND CSA OR CUL, MANUFACTURING DATE, MODEL # AND COUNTRY OF ORIGIN LABEL PROVIDED. RELAMPING LABEL FOR 150 WATT MAX. 3-WAY TYPE "A" BULB PROVIDED ON SOCKET.

PACKAGING AND SHIPPING DETAILS

HARP/FINIAL ARE REMOVED FOR SHIPPING. LAMP IS COVERED IN A CLOSED PLASTIC BAG WITH A SMALL BAG OF SILICA GEL INSIDE.

HARDWARE (4) PCS PLASTIC ANCHORS, (4) WOOD SCREWS, MOUNTING PLATE, (4) MOUNTING SCREWS, (2) NUTS, (2) CAP NUTS, CHANNEL AND (2) PCS CORD COVERS ARE PROVIDED

THE CARTON IS MADE OF DOUBLE WALL, CORRUGATED CARDBOARD. EXTERIOR SURFACE OF THE CARDBOARD IS FULL COLOR. THE INNER PACKING IS DIE-CUT CARDBOARD AND/OR MOLDED STYROFOAM SUFFICIENT TO PROTECT AND SECURE THE FIXTURE AND MUST PASS THE SPECIFIED DROP TEST REQUIREMENTS.

EACH CARTON SHALL BE PRINTED WITH A LINE DRAWING AND THE KENROY HOME NAME AND LOGO, MODEL NUMBER, SKU NUMBER AND FINISH, EACH CARTON SHALL BE PROVIDED A UPC LABEL. THE UPC BAR CODE AS FOLLOWS:
PB=053392159474.

OTHER DETAILS

SWING ARM, BACKPLATE, SOCKET COVER AND ALL EXPOSED PARTS MUST MATCH FINISH EXCEPT HARP.

MODEL 30130PB ASSEMBLY INSTRUCTIONS ARE TO BE PACKED WITH EACH LAMP AND PRINTED CLEARLY ON QUALITY PAPER.

ALL BAGS MUST BE LABELED WITH OFFICIAL "THIS BAG IS NOT A TOY" STATEMENT.

ASSEMBLY TIME: 5 MINUTES.

DIMS OF UNIT BOX: 32.7 CM (12-7/8") LENGTH x 12.4 CM (4-7/8") WIDTH x 33 CM (13") HEIGHT.

DIMS OF MASTER BOX: 67.3 CM (26-1/2") LENGTH x 40.3 CM (15-7/8") WIDTH x 35.6 CM (14") HEIGHT. (6 PCS/CTN)

THE UL NUMBER IS E124037-2.

**KENROY
HOME**

11660 CENTRAL PARKWAY
JACKSONVILLE, FL. 32224
PHONE: 904-642-4340
FAX: 904-642-4150

THIS DOCUMENT AND THE INFORMATION THAT IT DISCLOSES IS THE EXCLUSIVE PROPERTY OF KENROY HOME. ANY REPRODUCTION OR USE OF THIS DRAWING IN PART OR IN WHOLE, WITHOUT THE EXPRESS CONSENT OF THE PROPRIETOR IS PROHIBITED. © 1995 KENROY HOME.

DATE: 7/18/2006

SCALE: NONE

DRAWN BY: JAMES

REFERENCE:
SWING ARM CONVERTIBLE LAMP

APPROVAL:

REVISION DATE:
12/22/06 indicate 3-way bulb

REVISION DATE:
3/19/07 add finish of harp

REVISION DATE:
6/13/08 add parts NO.

REVISION DATE:
4/10/09 change to convertible lamp

MODEL #:

30130

FINISH: PB

PAGE: 1 OF 1