

5663527  
983ER019W06

**Notes:** 1) xxx represent different finishes.  
 2) (\*) Supplied with rough valve.

## Installation

Before the trim installation, confirm the valve depth to the finished wall surface ( dimension D on previous page drawing ).

If the valve depth fall in the range  $3'' 27/64 - 3'' 7/8$ , install the bellow component as supplied. If not, the component must be cutted, according to the actual valve depth (the component is grooved for that purpose).

If the valve depth fall in the range  $3'' 13/16 - 3'' 7/8$ , install the bellow components as supplied. If not, the components must be cutted, according to the actual valve depth (the components are grooved for that purpose).

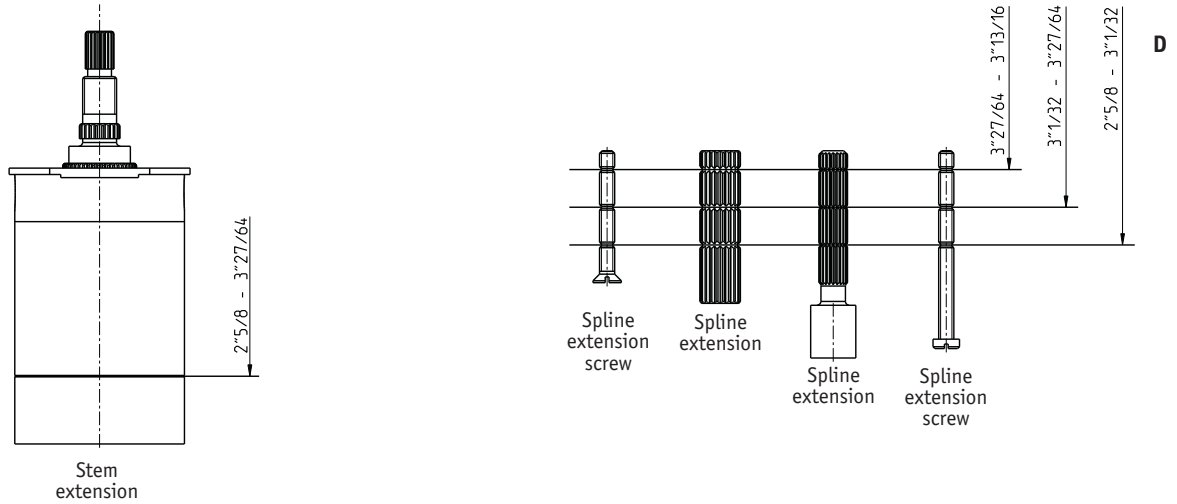

## Operation

The confort zone is in the range from 90°F to 100°F, but total range is 80°F to 110°F. Protection against scalding stops the rotation of the handle at 100°F. If water above 100°F is desired, press on the button and turn the knob counterclockwise, to prevent scalding, ensure that the handle is left in a previous position (= or <100°F).

## Thermostatic valve regulation (only when needed)

1. Remove the thermostatic handle control.
2. Confirm if the temperature limit stop on the spindle present its red mark coincident with the mark 100°F on the back plate; if not amend position.
3. Open the flow control valve, let the water run, and check by a thermometer the actual temperature delivered by the valve.  
It is advisable that you choose a temperature of 100°F when resetting the calibration. To accomplish that, rotate the spindle counterclockwise to increase the temperature or vice-versa. To rotate the spindle, you can use the thermostatic handle control while depressing the button, if necessary.
4. Achieving the temperature of 100°F, apply the handle aligning the button with the mark 100°F.
5. Valve setting is now calibrated according to your own operating conditions.
6. Secure the thermostatic handle control with the grub screw.

**Nota/Note:** It's recommended that you rotate the thermostatic control handle between the maximum and minimum limits, by pressing security button, and with the water running. This way you prevent limestone incrustation, that could block up the thermostatic cartridge.

