

Specification Sheet

Pendant

Model: **F1542-62 Metallic Silver**
F1542-68 Deep Bronze

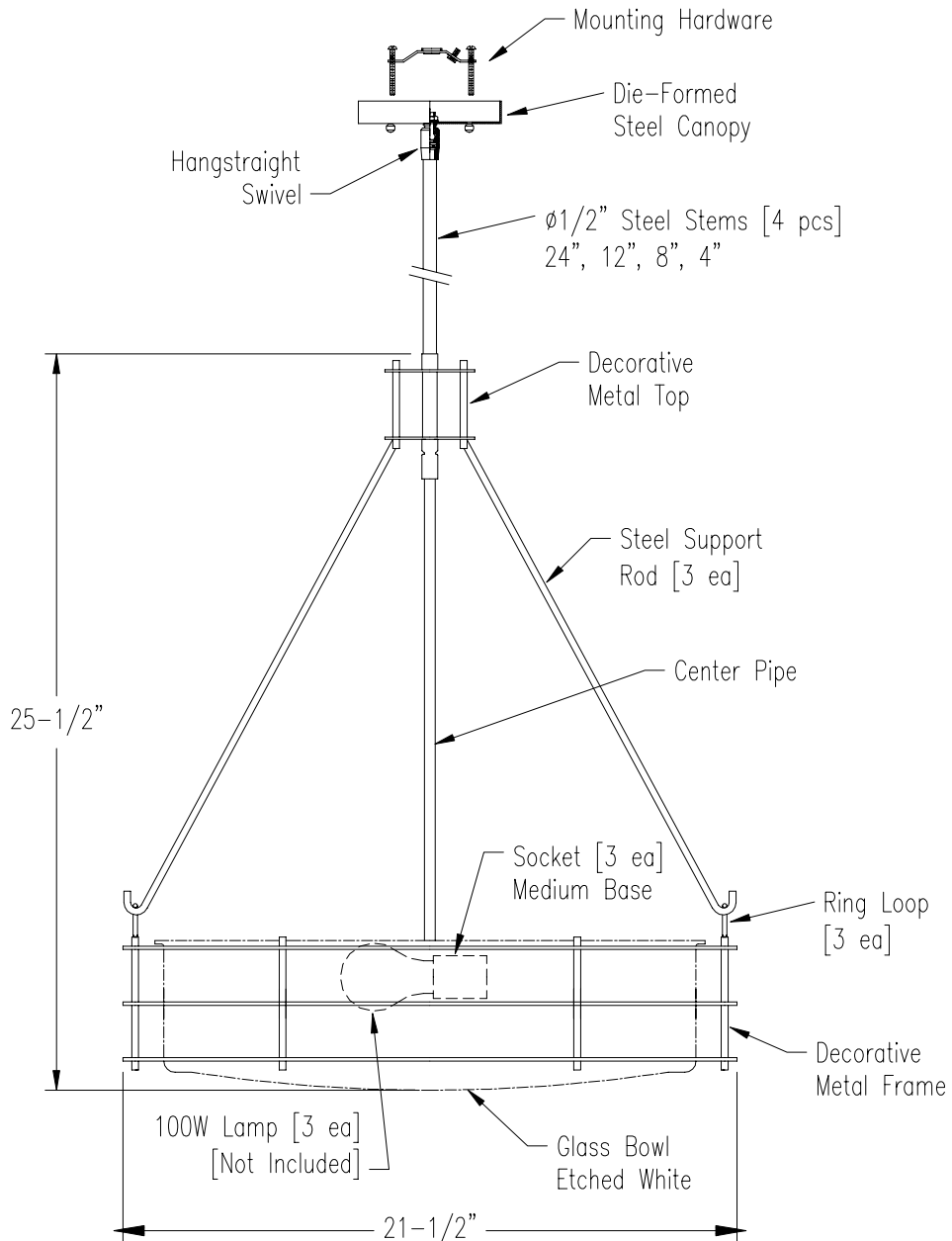

Glass: Etched White Opal

Metal Finishes: Metallic Silver (-62)

Deep Bronze (-68)

Width: 21-1/2" Height: 25-1/2" Overall Length: 75-1/2"

Lamps: 3 - 100 Watt Medium Base (not included)

Labels: cULus Listed. Suitable for Dry Locations.