

TECHNICAL DATA SHEET -

# ONEMount™ Flat Panel Modular Wall Mount for 23" - 84" Screens

## peerless®

MODELS: ONE-TP, ONE-TP-S,  
RTONE, RTONES



The **OneMount Flat Panel Modular Wall Mount** for 23" to 84" flat panel screens provides a versatile and secure solution for professional environments such as boardrooms, hotels and stadiums. This mount offers smooth, continuous tilt and IncreLok™ locking tilt, allowing for easy adjustment to achieve the perfect viewing angle without tools. The mount includes simple to align universal brackets and a unique wall plate that can be mounted to wood studs or concrete.

### Features:

- For virtually all 23" to 84" flat panel screens
- Adjustable 15° of forward tilt, 5° backward tilt
- Easy access knob for fine tension adjustment
- Tilt can be locked in place with the IncreLok™ locking tilt mechanism at -5, 0, +5, +10 & +15 degree increments
- The center of screen can be adjusted horizontally no more than 4" from center of wall plate configuration
- Mounts to wood studs, concrete, or to metal studs
- Universal tilt brackets easily hook onto the wall plate for fast installation
- Includes hardware for wood studs, concrete and cinder block
- Can also mount to two metal studs, up to 16" apart, using metal stud accessories
- All screen hardware included

### Accessories:

- ACC927, ACC927-S

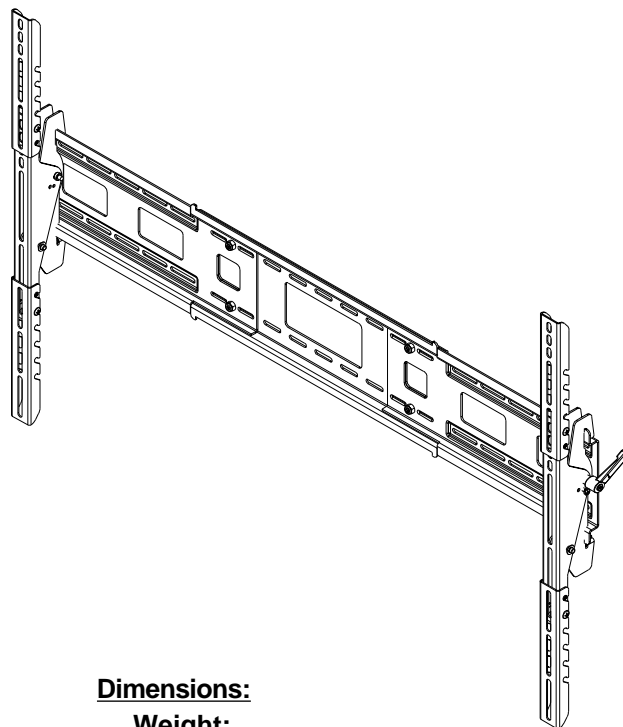

### Dimensions:

#### Weight:

16.34 lb (7.4 kg)

#### Shipping weight:

18.72 lb (8.45 kg)

#### Maximum Load Capacity:

250 lb (113.4 kg)

### Shipping Carton dimensions:

**L** = 20.5 in (521 mm)

**W** = 9.25 in (235 mm)

**H** = 5 in (127 mm)

## ARCHITECTS SPECIFICATIONS

The OneMount Flat Panel Modular Wall Mount for 23" to 84" shall be Peerless models \_\_\_\_\_ and shall be located where indicated on the plans. It shall feature adjustable 15° of forward tilt and 5° backward tilt. It shall be constructed of heavy gauge cold rolled steel and finished with scratch resistant Black or Silver Fused Epoxy. Assembly and installation shall be done according to instructions provided by the manufacturer.

### Peerless Industries, Inc.

3215 W. North Ave. Melrose Park, IL 60160  
708-865-8870 800-865-2112 Fax 708-865-2941

[www.peerlessmounts.com](http://www.peerlessmounts.com)

ISSUED: 09-20-06 SHEET NO: 202-9545-5 06-19-07

© 2007, Peerless Industries, Inc. All rights reserved.  
All other brand and product names are trademarks or registered trademarks of their respective owners.

TECHNICAL DATA SHEET

MODELS: ONE-TP, ONE-TP-S, RTONE, RTONES

All dimensions = inch (mm)

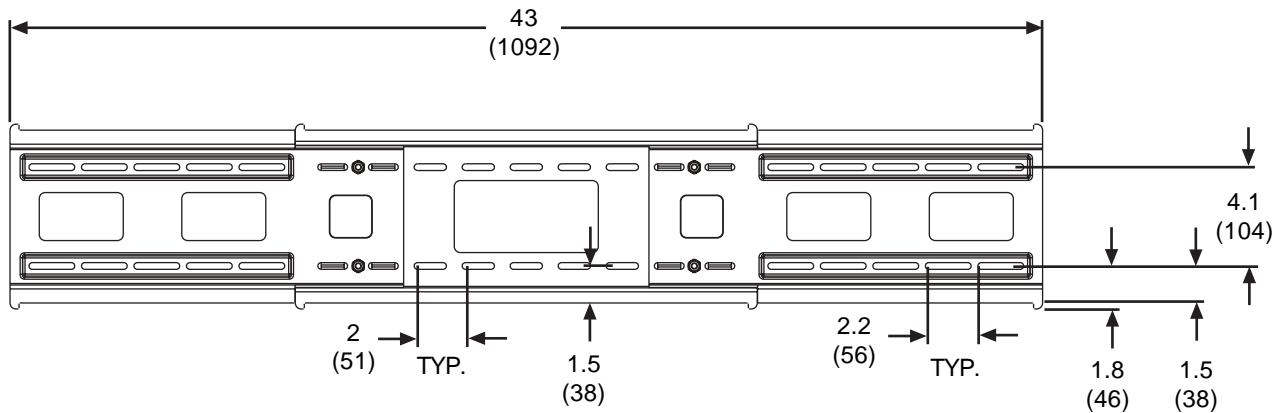
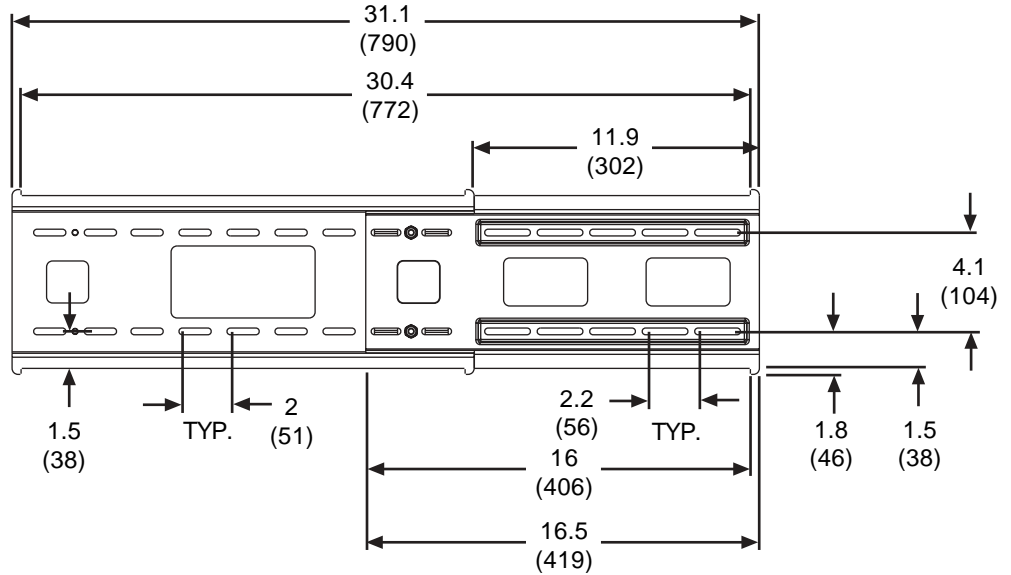
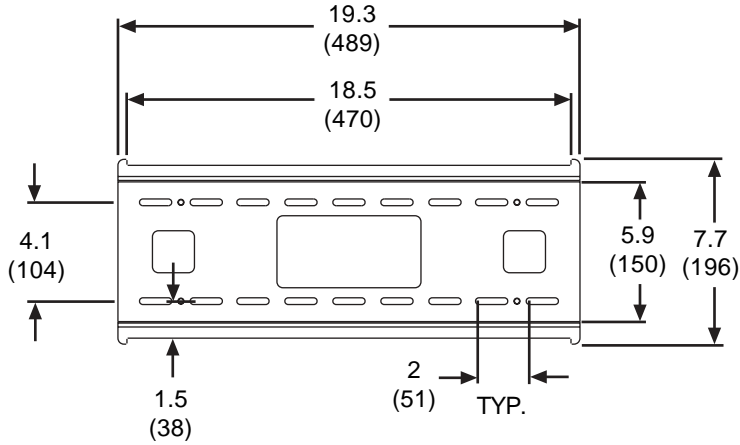

Wall Plate Configuration Details

TECHNICAL DATA SHEET

**MODELS:** ONE-TP, ONE-TP-S, RTONE, RTONES

All dimensions = inch (mm)

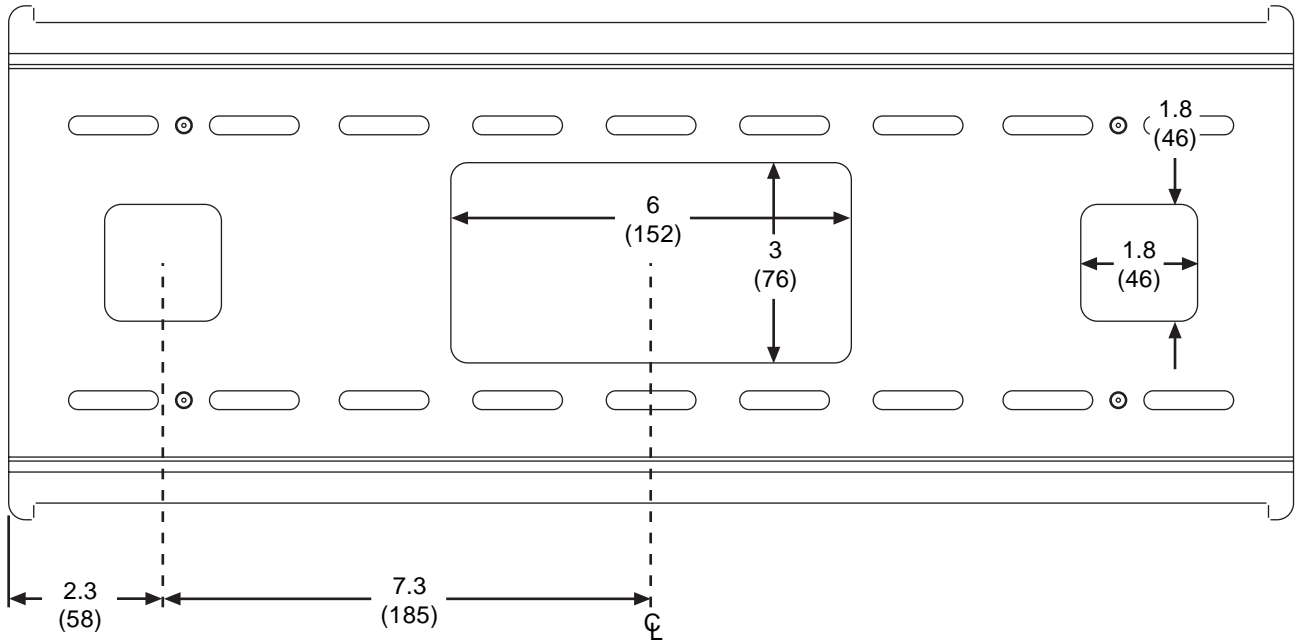

Wall Plate Detail

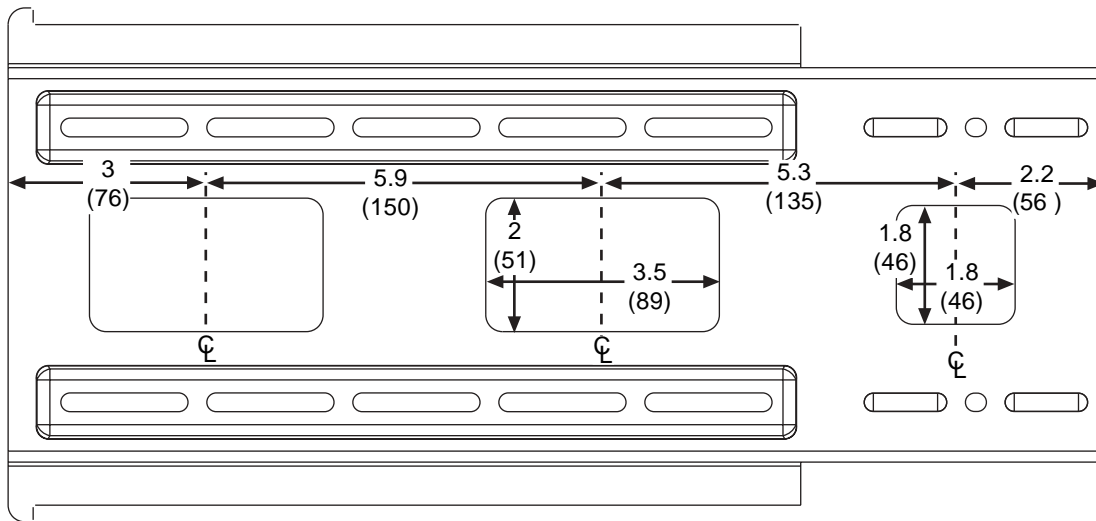

Wing Bracket Detail

TECHNICAL DATA SHEET

**MODELS: ONE-TP, ONE-TP-S, RTONE, RTONES**

All dimensions = inch (mm)

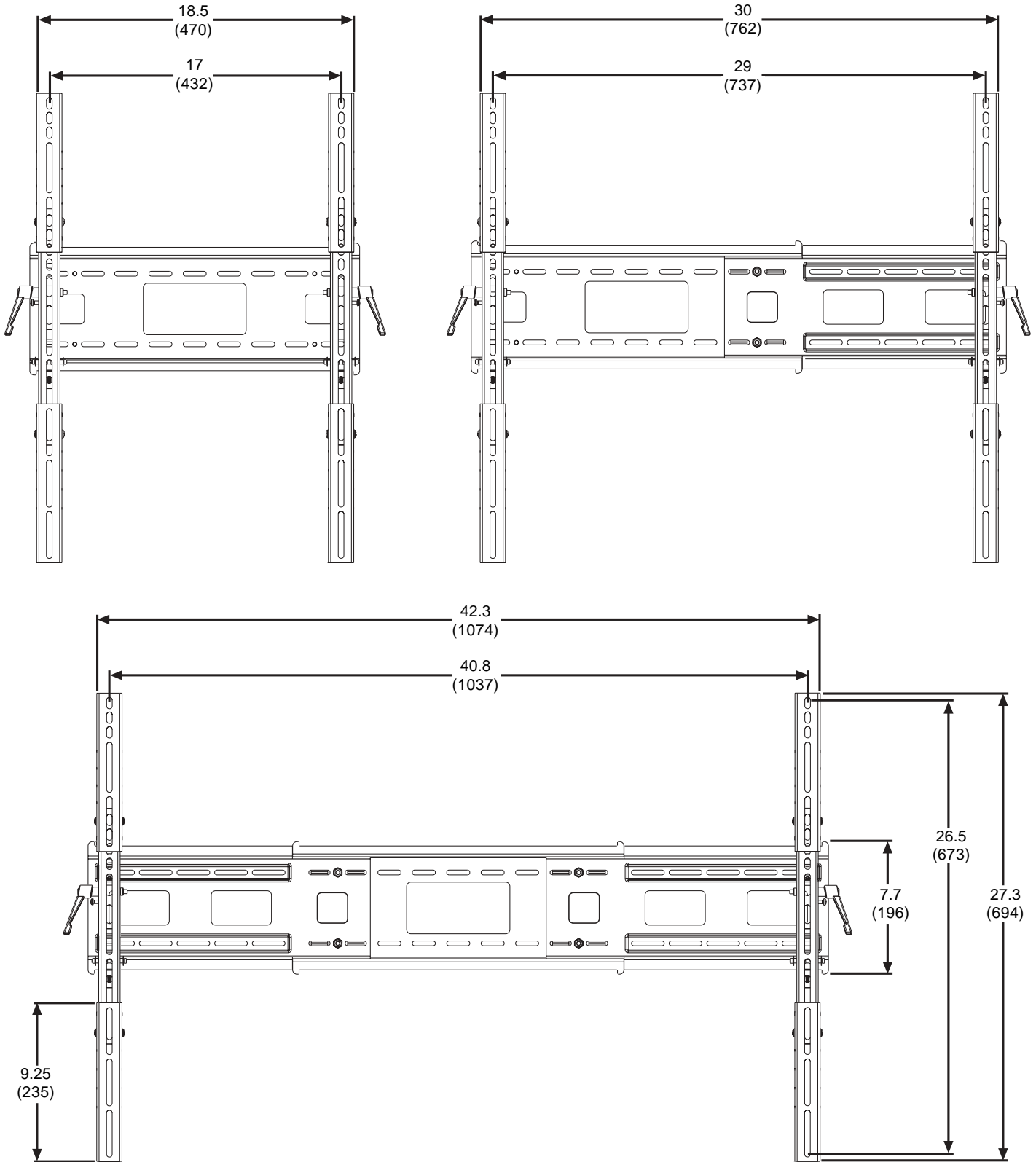

TECHNICAL DATA SHEET

MODELS: ONE-TP, ONE-TP-S, RTONE, RTONES

All dimensions = inch (mm)

