

**KITCHEN SINK FAUCET
K-12177**

FEATURES

- Metal construction
- One-piece self-contained ceramic disc valve allows both volume and temperature control
- Temperature memory allowing faucet to be turned on and off at any temperature setting
- High-temperature limit stop
- 9" Swing spout with integral spray and retractable hose
- 2.2 gallons per minute (Max. @ 60 psi)
- Lever handle
- Touch control stream-to-spray adjustment
- Integral vacuum breaker
- 10" Escutcheon plate for three-hole installations

ADA

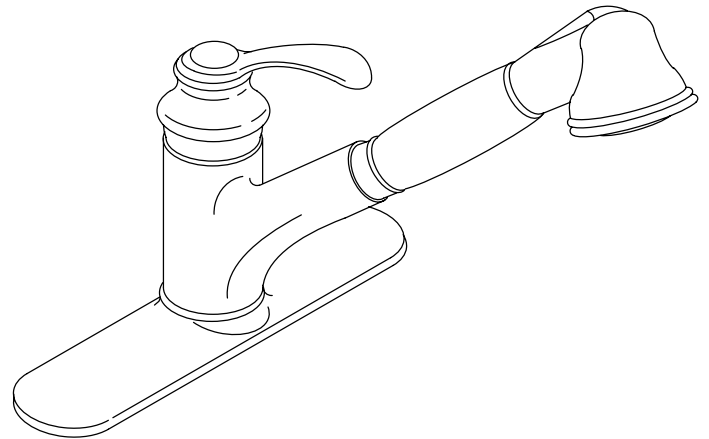

CODES/STANDARDS APPLICABLE

Specified model meets or exceeds the following:

- ASME/ANSI A112.18.1M
- CSA International B125
- Energy Policy Act of 1992
- IAPMO/UPC listed
- NSF 61
- Listed in the State of Wisconsin

COLORS/FINISHES

- CP Polished Chrome
- PB Polished Brass
- Other Refer to Faucets Price Book for additional finish

SPECIFIED MODEL:

Model	Description	<input type="checkbox"/> CP	<input type="checkbox"/> PB	<input type="checkbox"/> Other_____
K-12177	With Matching Color Sprayhead			

PRODUCT SPECIFICATION:

Single-control pull-out spray kitchen sink faucet shall be of metal construction. The valve shall be a one-piece, self-contained ceramic disc valve, and allows both volume and temperature control. The valve shall feature temperature memory, allowing the faucet to be turned on and off at any temperature setting, and includes a high-temperature limit stop. Faucet shall also feature stream-to-spray touch control. Product shall include 9" swing spout with integral sprayhead and hose, lever handle, integral vacuum breaker, and 10" escutcheon plate. Faucet shall be Kohler Model K-12177-_____.

Roughing-In Notes

Meets all local plumbing codes for vacuum breaker requirements.

All necessary parts included for both single-hole and three-hole installation.

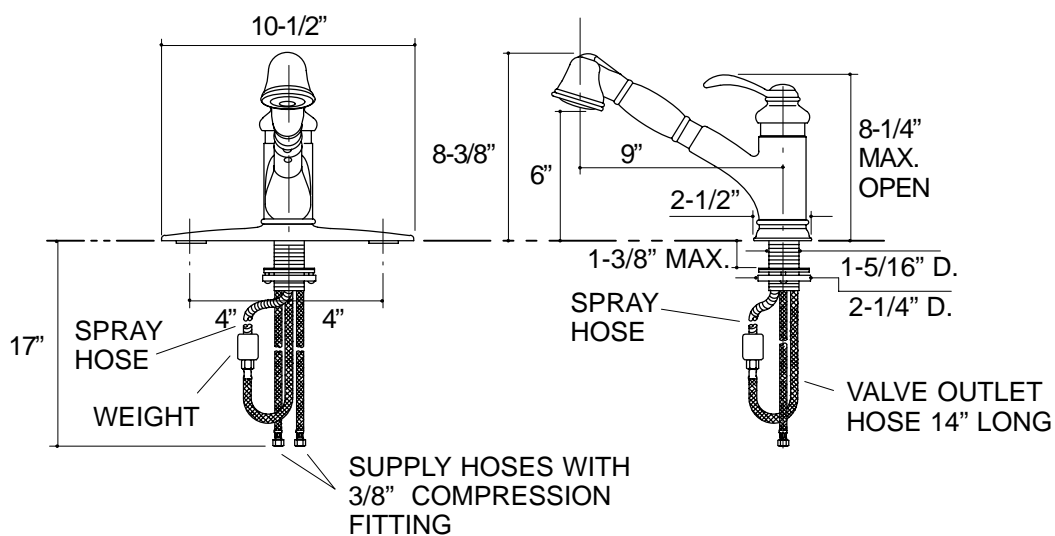

PRODUCT DIAGRAM