

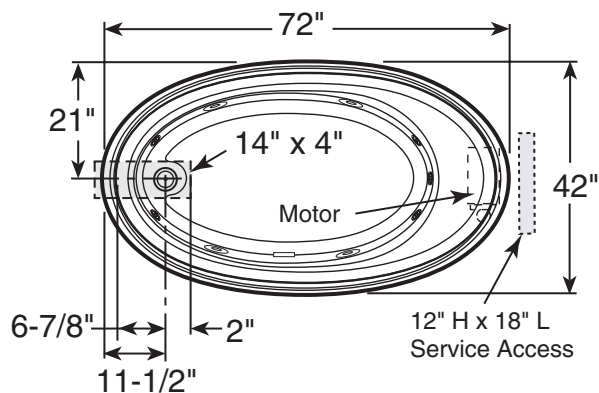

Gallery™ 6 Whirlpool Plus Bath

- ER50 Gallery™ 6 Oval Whirlpool Plus Bath Left Hand
- ER60 Gallery™ 6 Oval Whirlpool Plus Bath Right Hand

- Right and Left Hand Drain Location
- Accessories / Hardware:
 - TheraPro™ Jet Rings #GU44
 - AccuPro™ Jet Rings #GU45 (2 kits required)
 - Trip-Lever Drain Kit: #X559
 - Rotary Drain Kit, 26" Cable: #8730
- Trim Kit Finishes Available:
 - (827) – Chrome
 - (826) – Brushed Nickel
 - (845) – Oil Rubbed Bronze



Product Shown: Gallery™ 6 Oval Whirlpool Plus Bath, Left Hand
Shown Model: ER50

* Measurements inside unit represent cutout in floor to allow for drain/overflow.
 Minimum Service Access dimensions given.

INSTALLATION NOTES

Refer to installation instructions included with fixture before beginning installation. Please confirm product availability and specifications before commencing with any installation work.

PRODUCT SPECIFICATIONS AND AVAILABILITY ARE SUBJECT TO CHANGE WITHOUT NOTICE.

Technical Specifications

DIMENSIONS

72" L x 42" W x 20-1/2" H
 (1829 mm) L x (1067 mm) W x (521 mm) H

DRAIN/OVERFLOW

A: 16" (406 mm) B: 11-1/2" (292 mm)

CUTOUT

Template Provided, PN 186000

TOTAL WEIGHT

1096 lb (497 kg) / 52 lb/sq. ft. (254 kg/m²)

OPERATING GALLONAGE

Min. 58 U.S. Gal. (220 Liters)
 Max. 89 U.S. Gal. (337 Liters)

PRODUCT WEIGHT

105 lb (48 kg)

SKIRT MOUNTING

Not Available

ELECTRICAL SPECIFICATIONS

Requires a dedicated GFCI protected separate circuit.
 Motor/Pump: 120 VAC, 15 AMP, 60 Hz.
 RapidHeat™: 120 VAC, 15 AMP, 60 Hz.

HEATER

Requires a dedicated GFCI protected separate circuit.
 RapidHeat™: P/N S750000

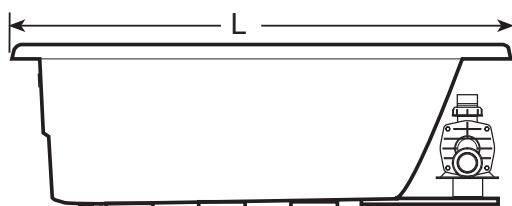

SIDE VIEW

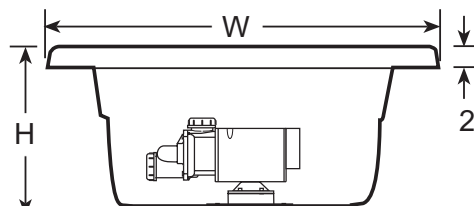

END VIEW

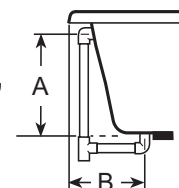

DRAIN/OVERFLOW