



# Gallery™ 5 Oval Whirlpool Bath

N845 Gallery™ 5 Oval Whirlpool Bath Left Hand

N850 Gallery™ 5 Oval Whirlpool Bath Right Hand

# Gallery™ 5 Oval Soaker Bath

N855 Gallery™ 5 Oval Bath

- Left and Right Hand Drain Locations
- Accessories / Hardware:
  - Trip-Lever Drain Kit: #X559
  - Rotary Drain Kit, 26" Cable #8730
  - TheraPro™ Jet Rings #GU44
  - AccuPro™ Jet Rings #GU45
- Trim Kit Finishes Available:
  - (827) – Chrome
  - (826) – Brushed Nickel
  - (849) – Oil Rubbed Bronze

## INSTALLATION NOTES

Refer to installation instructions included with fixture before beginning installation. Please confirm product availability and specifications before commencing with any installation work.

PRODUCT SPECIFICATIONS AND AVAILABILITY ARE SUBJECT TO CHANGE WITHOUT NOTICE.

## Technical Specifications

### DIMENSIONS

62" L x 43" W x 19" H  
(1575 mm) L x (1092 mm) W x (543 mm) H

### DRAIN/OVERFLOW

A: 14-3/4" (375 mm) B: 9-1/2" (241 mm)

### CUTOUT

Template Provided P/N P186000

### TOTAL WEIGHT

N845, N850: 798 lb (362 kg) / 43 lb/sq. ft. (210 kg/m<sup>2</sup>)  
N855: 751 lb (341 kg) / 41 lb/sq. ft. (200 kg/m<sup>2</sup>)

### OPERATING GALLONAGE

Min. 42 U.S. Gal. (197 Liters)  
Max. 54 U.S. Gal. (204 Liters)

### PRODUCT WEIGHT

N845, N850: 98 lb (44 kg)  
N855: 51 lb (23 kg)

### SKIRT MOUNTING

Not Available

### ELECTRICAL SPECIFICATIONS - Models N845, N850 only

Requires a dedicated GFCI protected separate circuit.

Motor/Pump: 120 VAC, 15 AMP, 60 Hz.

RapidHeat™: 120 VAC, 15 AMP, 60 Hz.

### HEATER (OPTIONAL) - Models N845, N850 only

Requires a dedicated GFCI protected separate circuit.

RapidHeat™: P/N S750000

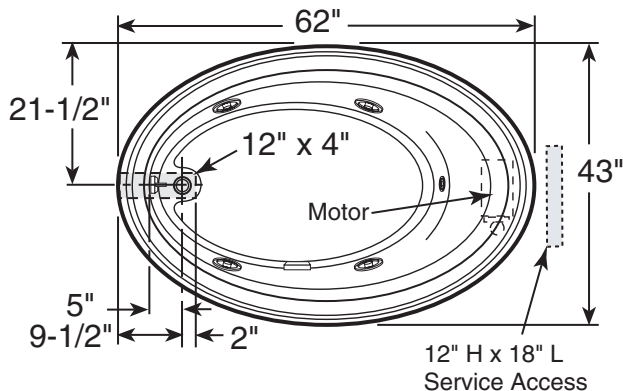

Product Shown: Gallery™ 5 Oval Whirlpool Bath Left Hand

Shown Model: N845

\* Measurements inside unit represent cutout in floor to allow for drain/overflow.

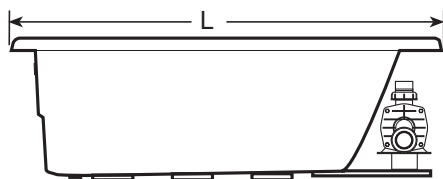

SIDE VIEW

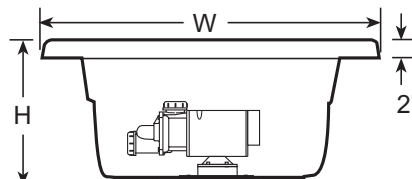

END VIEW

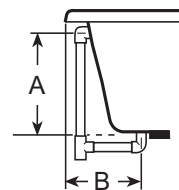

DRAIN/OVERFLOW