



# Gallery™ 5 Whirlpool Plus Bath

**ER30** Gallery™ 5 Whirlpool Plus Bath Left Hand

**ER40** Gallery™ 5 Whirlpool Plus Bath Right Hand

- Left and Right Hand Drain Locations
- Accessories / Hardware:
  - Trip-Lever Drain Kit: #X559
  - Rotary Drain Kit, 26" Cable #8730
  - TheraPro™ Jet Rings #GU44
  - AccuPro™ Jet Rings #GU45 (2 kits required)
- Trim Kit Finishes Available:
  - (827) – Chrome
  - (826) – Brushed Nickel
  - (849) – Oil Rubbed Bronze

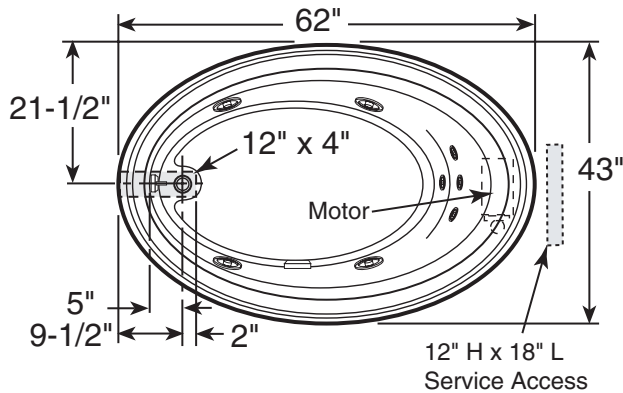

**Product Shown: Gallery™ 5 Oval Whirlpool Plus Left Hand**  
**Shown Model: ER30**

\* Measurements inside unit represent cutout in floor to allow for drain/overflow.

## INSTALLATION NOTES

Refer to installation instructions included with fixture before beginning installation. Please confirm product availability and specifications before commencing with any installation work.

PRODUCT SPECIFICATIONS AND AVAILABILITY ARE SUBJECT TO CHANGE WITHOUT NOTICE.

## Technical Specifications

### DIMENSIONS

62" L x 43" W x 19" H  
 (1575 mm) L x (1092 mm) W x (543 mm) H

### DRAIN/OVERFLOW

A: 14-3/4" (375 mm) B: 9-1/2" (241 mm)

### CUTOUT

Template Provided P/N P186000

### TOTAL WEIGHT

829 lb (376 kg) / 45 lb/sq. ft. (220 kg/m<sup>2</sup>)

### OPERATING GALLONAGE

Min. 40 U.S. Gal. (151 Liters)  
 Max. 58 U.S. Gal. (220 Liters)

### PRODUCT WEIGHT

96 lb (44 kg)

### SKIRT MOUNTING

Not Available

### ELECTRICAL SPECIFICATIONS

**Requires a dedicated GFCI protected separate circuit.**

Motor/Pump: 120 VAC, 15 AMP, 60 Hz.

RapidHeat™: 120 VAC, 15 AMP, 60 Hz.

### HEATER

**Requires a dedicated GFCI protected separate circuit.**

RapidHeat™: P/N S750000



SIDE VIEW

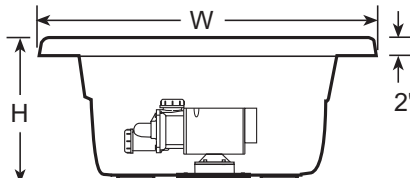

END VIEW

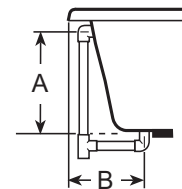

DRAIN/OVERFLOW