









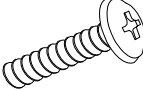

STYLE NO. DN1439
JCP LOT#781-3510

SOUTHERN ENTERPRISES INC.

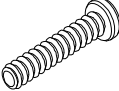
**3-PC NANTUCKET
BREAKFAST SET**

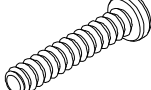
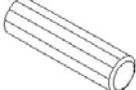
RELAX...If you can follow a few easy, step-by-step directions in order .YOU CAN ASSEMBLE THIS ITEM.

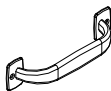
PLEASE FIND HARDWARE IN RED POLYBAG BEFORE DISCARDING PACKING MATERIAL.

HARDWARE LIST			
(1) MEDIUM MACHINE SCREW  (Ø5/16"X1-1/2")	8PCS	(6) WOOD SCREW 	11PCS
(2) SHORT MACHINE SCREW  (Ø5/16"X1")	14PCS	(7) T-BOLT 	18PCS
(3) LONG MACHINE SCREW  (Ø5/16"X2-1/2")	18PCS	(8) WOOD DOWEL 	48PCS
(4) WRENCH 	1PC	(9) WOOD PLUG 	24PCS
(5) METAL HANDLE 	1PC	(10) DRAWER STOPPER 	1PC

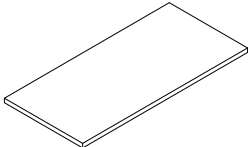
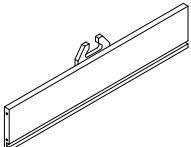
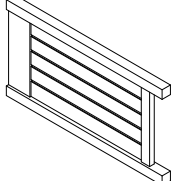
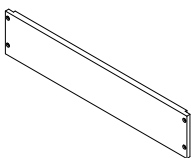
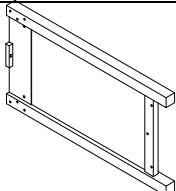
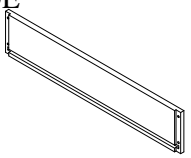
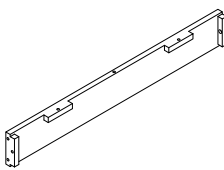
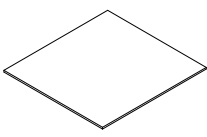
PARTS LIST			
(A) TOP 	1PC	(K) DRAWER BACK 	1PC
(B) LEFT SIDE PANEL 	1PC	(L) DRAWER LEFT SIDE 	1PC
(C) RIGHT SIDE PANEL 	1PC	(M) DRAWER RIGHT SIDE 	1PC
(D) BACK PANEL 	1PC	(N) DRAWER BOTTOM 	1PC

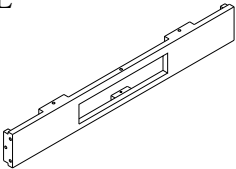
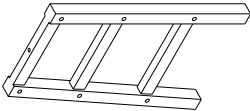
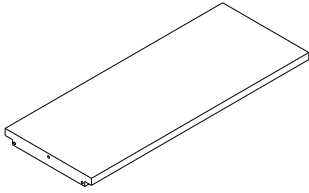
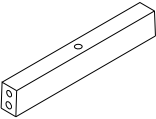
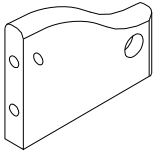
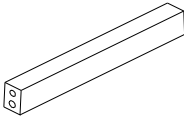
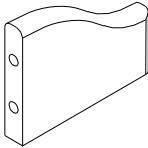
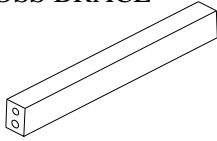
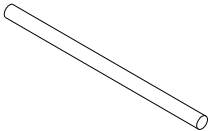
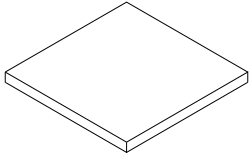
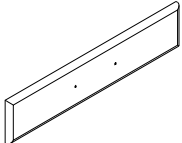
<p>(E) FRONT PANEL 1PC</p> 	<p>(O) SIDE FRAME 4PCS</p> 
<p>(F) SHELF 1PC</p> 	<p>(P) UPPER CROSS BRACE 4PCS</p> 
<p>(G) RIGHT HOLDER 1PC</p> 	<p>(Q) MIDDLE CROSS BRACE 4PCS</p> 
<p>(H) LEFT HOLDER 1PC</p> 	<p>(R) LOWER CROSS BRACE 4PCS</p> 
<p>(I) WOOD BAR 1PC</p> 	<p>(S) SEAT PANEL 2PCS</p> 
<p>(J) DRAWER FRONT 1PC</p> 	

ASSEMBLY INSTRUCTIONS

1. SELECT A SMOOTH, SOFT SURFACE TO PREVENT SCRATCHING FINISH.
2. YOU MAY NEED A PHILLIP SCREWDRIVER.
3. INSERT WOOD DOWELS (8) INTO PREDRILLED HOLES ON ENDS OF SHELF (F), FRONT AND BACK PANELS (E, D) AND FIT INTO CORRESPONDING HOLES ON INSIDE OF LEFT AND RIGHT SIDE PANELS (B, C). INSERT SHORT MACHINE SCREWS (2) THROUGH PREDRILLED HOLES ON WOOD BARS ON PARTS (D, E, F) AND TIGHTEN INTO PRETHREADED HOLES ON LEFT AND RIGHT SIDE PANELS (B, C) BY USING WRENCH (4). (AS SHOWN IN FIGURE 1)
4. INSERT WOOD DOWELS (8) INTO PREDRILLED HOLES ON UNDERSIDE OF TOP (A) AND FIT INTO CORRESPONDING HOLES ON EDGES OF FRONT AND BACK PANELS (E, D). INSERT SHORT MACHINE SCREWS (2) THROUGH PREDRILLED HOLES ON WOOD BARS ON PARTS (B, C, D, E) AND TIGHTEN INTO PRETHREADED HOLES ON UNDERSIDE OF TOP (A) BY USING WRENCH (4). (AS SHOWN IN FIGURE 2)
5. FIT WOOD BAR (I) INTO THE HOLES ON LEFT AND RIGHT HOLDERS (G, H). INSERT WOOD DOWELS (8) INTO PREDRILLED HOLES ON LEFT AND RIGHT HOLDERS (G, H) AND FIT INTO CORRESPONDING HOLES ON OUTSIDE OF RIGHT SIDE PANEL (C). INSERT T-BOLTS (7) INTO THE HOLES ON LEFT AND RIGHT HOLDERS (G, H), AND TIGHTEN LONG MACHINE SCREWS (3)

THROUGH PREDRILLED HOLES ON RIGHT SIDE PANEL (C) INTO T-BOLTS (7) BY USING WRENCH (4). PLEASE NOTE THAT IF SCREWS DO NOT TIGHTEN, ROTATE T-BOLTS (7) SO THAT THREAD OF T-BOLTS ARE FACING SCREWS. (AS SHOWN IN FIGURE 2)

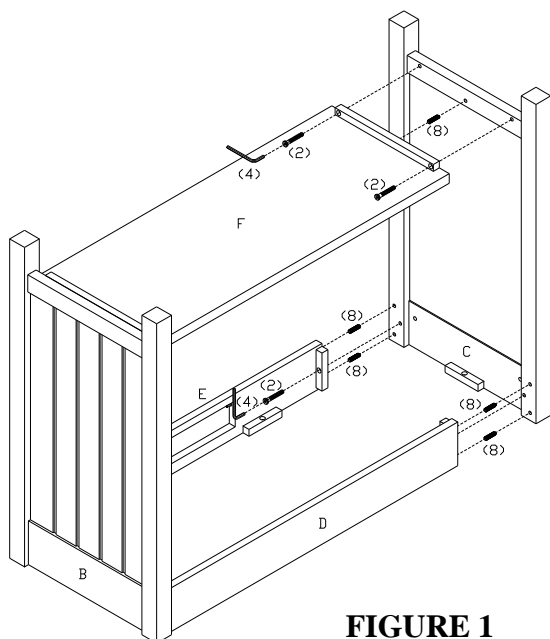

FIGURE 1

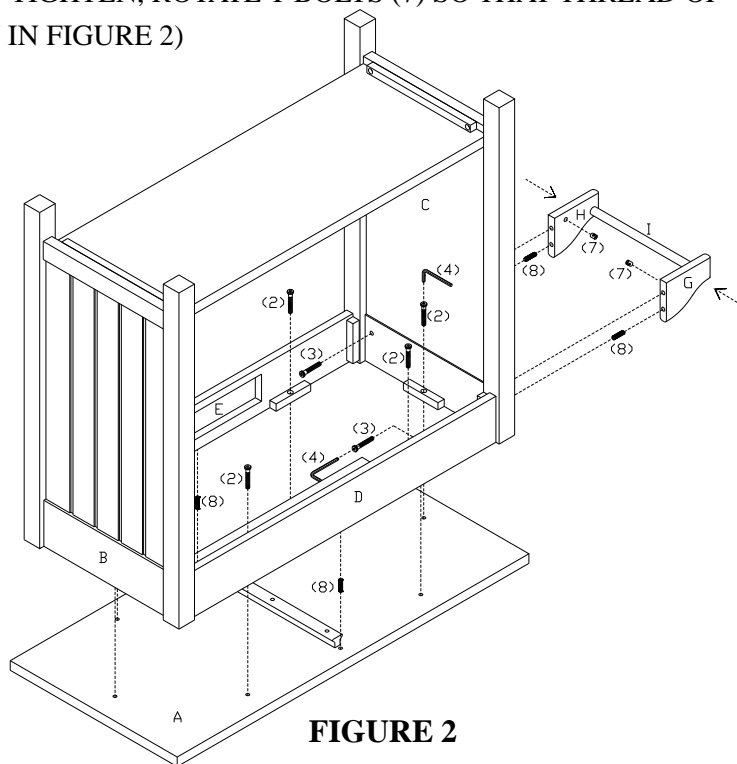

FIGURE 2

6. INSERT WOOD SCREWS (6) THROUGH PREDRILLED HOLES ON OUTSIDE OF DRAWER LEFT SIDE (L) AND TIGHTEN INTO CORRESPONDING HOLES ON ENDS OF DRAWER FRONT AND BACK (J, K). SLIDE DRAWER BOTTOM (N) INTO GROOVES ON INSIDE OF DRAWER FRONT AND BACK (J, K) AND ALIGN WITH THE GROOVE ON DRAWER LEFT SIDE (L). REPEAT SAME PROCEDURE FOR DRAWER RIGHT SIDE (M). INSERT WOOD SCREWS (6) THROUGH METAL HANDLE (5) AND TIGHTEN INTO PREDRILLED HOLES ON DRAWER FRONT (J). **INSERT WOOD SCREW (6) THROUGH DRAWER STOPPER (10) AND TIGHTEN INTO PREDRILLED HOLE ON FRONT PANEL (E). THEN PLACE THE ASSEMBLED DRAWER INTO SPACE OF BAR TABLE. (AS SHOWN IN FIGURES 3 & 4).**

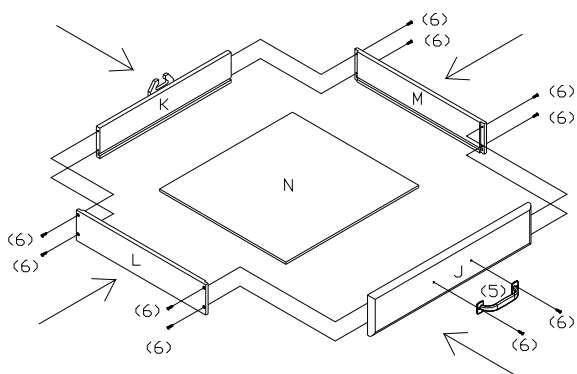

FIGURE 3

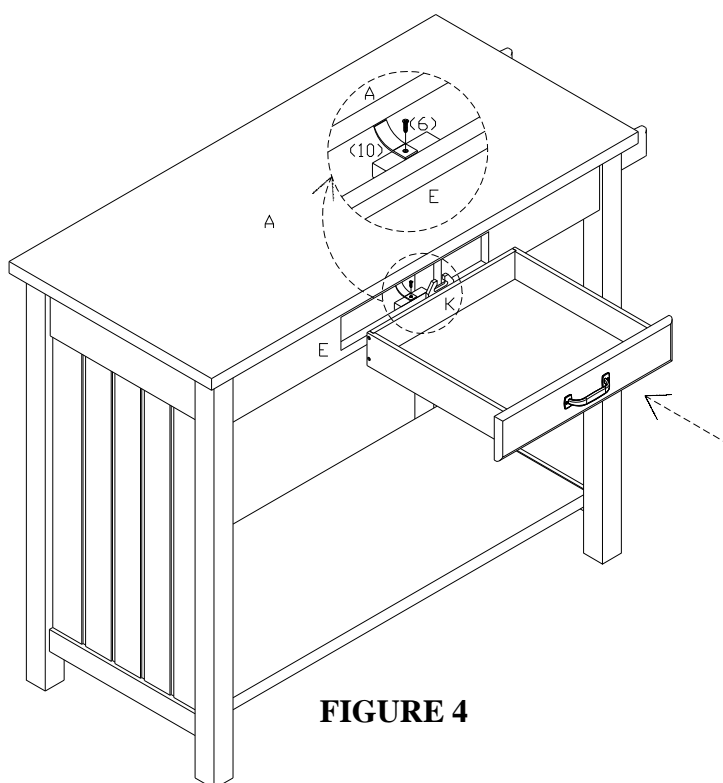

FIGURE 4

7. INSERT WOOD DOWELS (8) INTO PREDRILLED HOLES ON ENDS OF PARTS (P, Q, R) AND FIT INTO CORRESPONDING HOLES ON SIDE FRAMES (O), FIT T-BOLTS (7) INTO THE HOLES ON PARTS (P, R). AND TIGHTEN LONG MACHINE SCREWS (3) THROUGH PREDRILLED HOLES ON SIDE FRAMES (O) INTO T-BOLTS (7) BY USING WRENCH (4). PUSH WOOD PLUGS (9) INTO THE HOLES ON OUTSIDE OF SIDE FRAMES (O). PLEASE NOTE THAT IF SCREWS DO NOT TIGHTEN, ROTATE T-BOLTS (7) SO THAT THREAD OF T-BOLTS ARE FACING SCREWS. (AS SHOWN IN FIGURE 5)
8. INSERT MEDIUM MACHINE SCREWS (1) THROUGH PREDRILLED HOLES ON SIDE FRAMES (O) AND TIGHTEN INTO PRETHREADED HOLES ON UNDERSIDE OF SEAT PANEL (S). (AS SHOWN IN FIGURE 6)

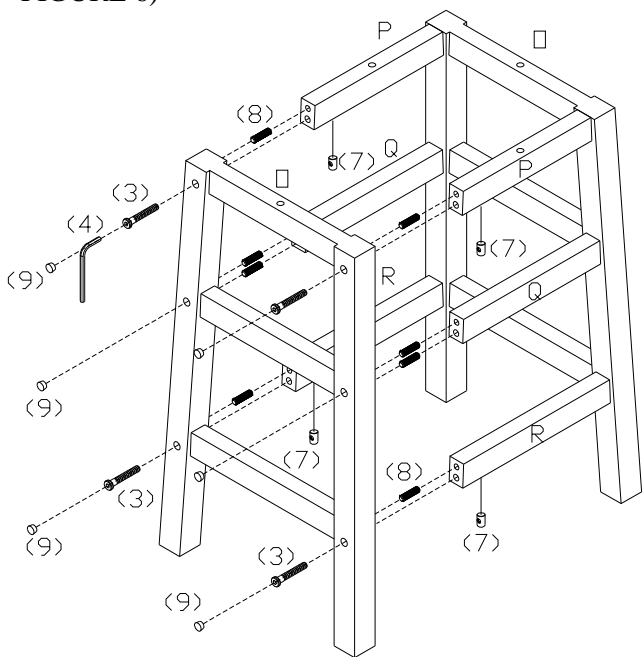

FIGURE 5

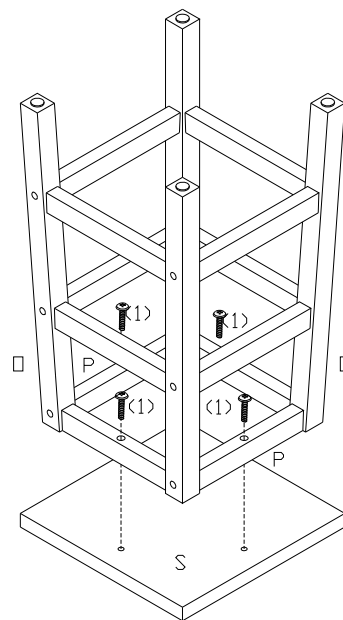
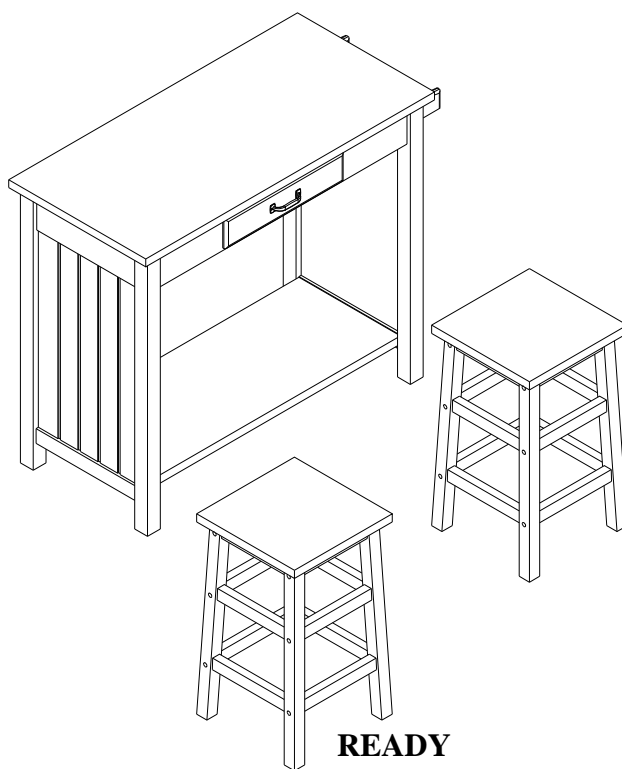

FIGURE 6



READY

YOUR NEW 3-PC NANTUCKET BREAKFAST SET IS FINISHED AND READY TO USE.

Please count, identify and compare parts and hardware list to be sure all parts are present. It may help to divide parts and label them to correspond with part list. Extra hardware may be included. If any items are missing, please contact our parts/service department at (800) 633-5096 or in Dallas (972) 869-0111/ 9am – 4pm Mon-Fri Central time. Missing or damaged hardware and/ or parts will be replaced free of charge. WE DO NOT SELL PARTS. WE DO NOT RECOMMEND MODIFYING PRODUCT(S) AND WE ARE NOT RESPONSIBLE FOR ANY DAMAGES DUE TO PRODUCT MODIFICATION(S). If this product has not been purchased from our retail affiliates (within 9 months), we are under no obligation to provide parts or replacement merchandise. Parts will not be available for items arriving fully assembled.

"We will ship parts if available" "This is not a warranty"

PARTS REPLACEMENT FORM			
STYLE NO: DN1439 JCP LOT#781-3510			
Customer Name	PARTS LETTER	PART DESCRIPTION	QUANTITY NEEDED
<hr/> Street, City, State, Zip			
<hr/> Phone#			
		<hr/> Please indicate where you purchased this item. Store/website/catalog / /	
SOUTHERN ENTERPRISES INC. P.O. Box 59996 Dallas, Texas 75229		<hr/> Please indicate color/size/style number / /	