

CK884200TX

**Addison End Table
Assembly Instruction**



For assistance with assembly contact:
Southern Enterprises Inc.
Customer Service 1-800-633-5096
service@seidal.com
www.seidal.com

Max load 20 lb.

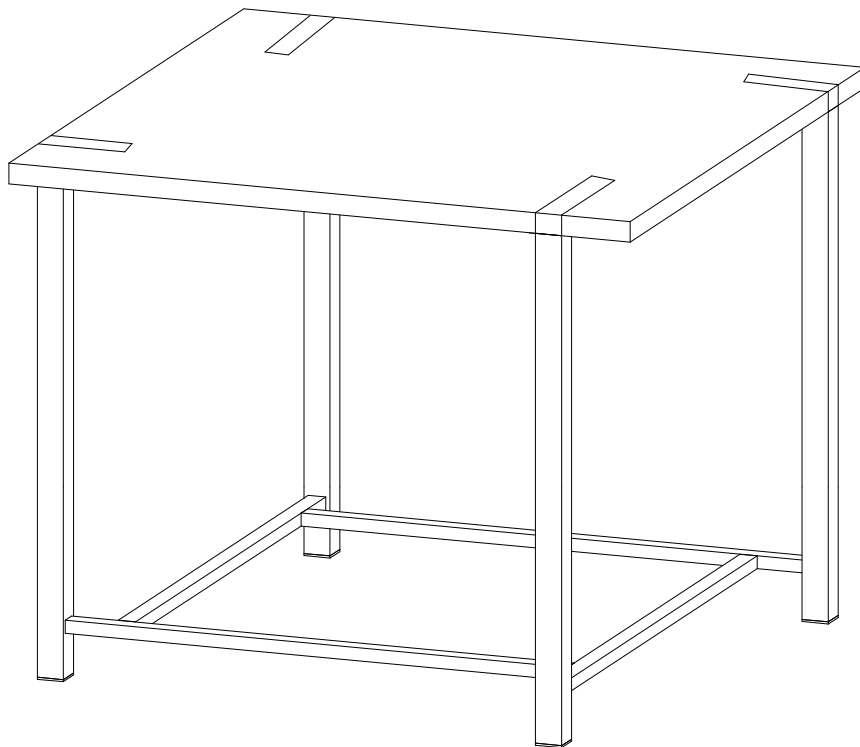





CK884200TX

Addison End Table

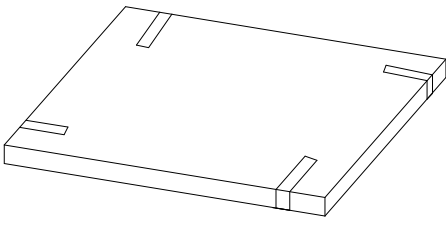
Parts List

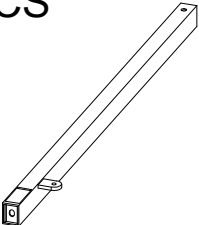
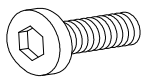
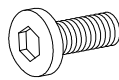
Please review all parts and hardware before disposing of any packaging. Call Customer Service if missing hardware. Do not return to store/retailer. Screws shown actual size. Using a screw that is too long will cause damage. Before beginning assembly, separate each type of screw. Carefully study the screw diagrams below.

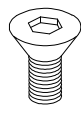
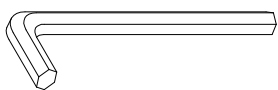
<p>1 1PC</p>  <p>Wood Top</p>	<p>2 4PCS</p>  <p>Leg</p>	<p>3 4PCS</p>  <p>Stretcher</p>
<p>A 4PCS</p>  <p>Screw (1/4"x15mm)</p>	<p>B 4PCS</p>  <p>Screw (1/4"x12mm)</p>	<p>C 4PCS</p>  <p>Lock washer</p>
<p>D 8PCS</p>  <p>Screw (1/4"x15mm)</p>	<p>E 1PC</p>  <p>Wrench</p>	

Care and Cleaning Instructions:
 Before using, wipe with a clean, dry cloth.
 Periodically apply furniture wax to renew the finish. Avoid rubbing or scratching the surface with rough or abrasive objects.

For replacement parts or questions, please Call Customer Service at 1-800-633-5096
 Do not return product to store, please call manufacturer for assistance, questions or parts.

Assembly Tool Required
No.2 Phillips Screwdriver

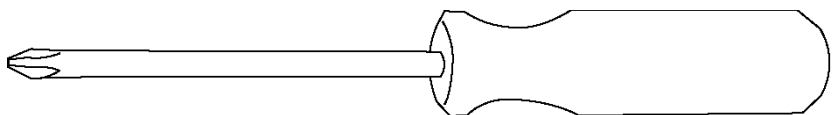

CK884200TX

Addison End Table

Assembly Instruction

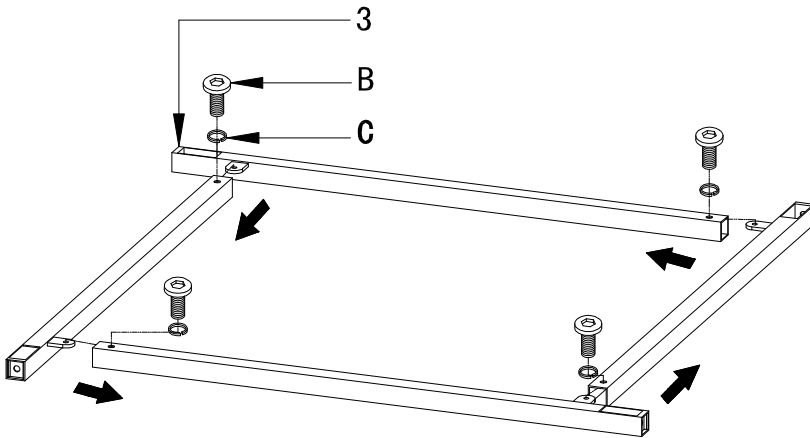

Figure 1

Step 1:

Put all parts on a soft surface to prevent scratches.

Combine stretcher (3) by using screw (B) and washer (C) as shown.

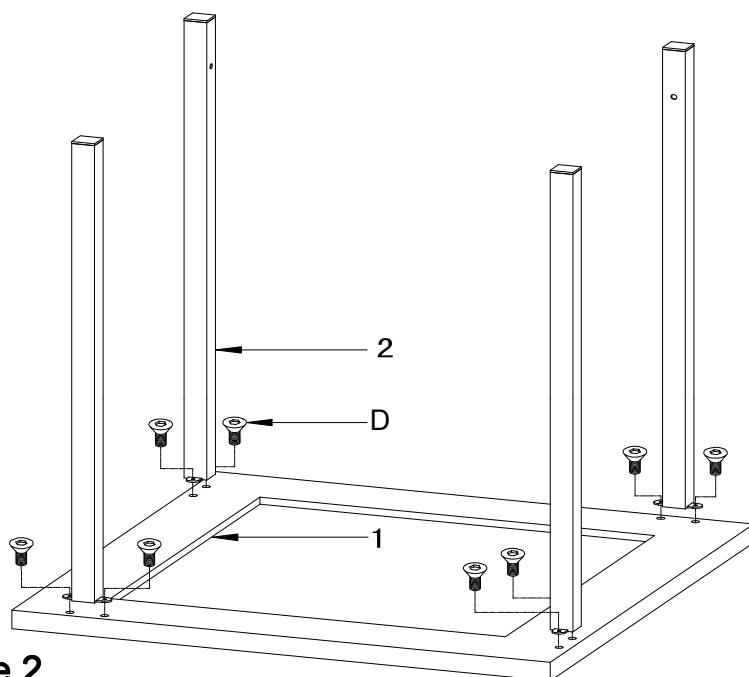

Figure 2

Step 2:

Attach Leg (2) to wood top (1) by using screw (D) as shown.

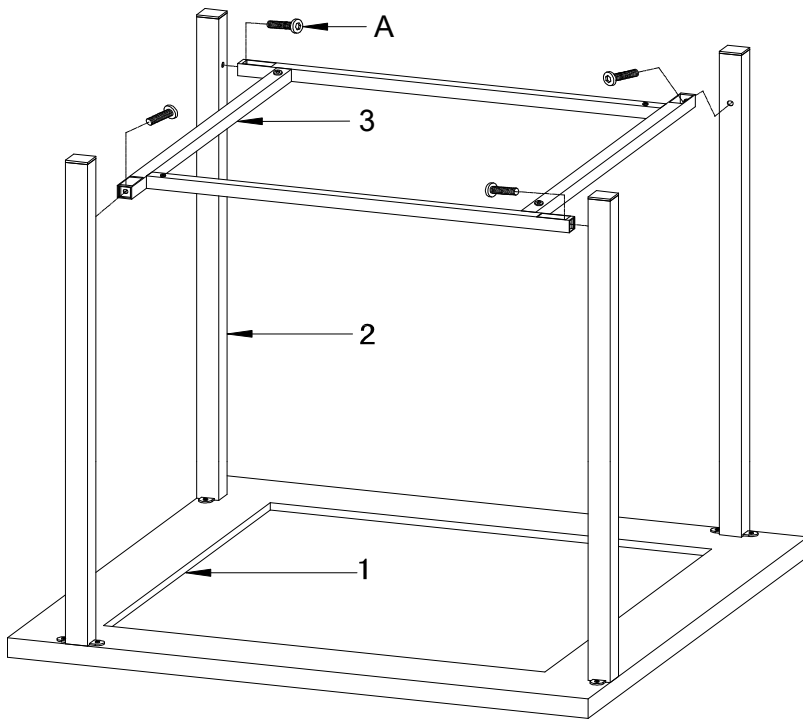

Figure 3

Step 3:

Attach stretcher frame to leg (2) by using screw (A) as shown.



Customer Service 1-800-633-5096
service@seidal.com
Southern Enterprises, Inc.
600 Freeport Parkway Suite 200
Coppell, Texas 75019

We'd love to hear from you! Email us photos of our products in your home at sei@seidal.com and we might feature it on our site or use it to model one of our inspirational photos.

“PARTS WILL BE SENT IF AVAILABLE FROM SEI”

Parts Replacement Form

Customer Information

Name _____

Address _____

City/State/Zip Code _____

Phone Number _____

Please indicate where you purchased this item: Store/ Website/ Catalog

Please indicate color/size/style number:

Style No	Parts Letter	Parts Description	Quantity Needed

Missing or damaged hardware and/ or parts will be replaced free of charge. We do not sell parts. Southern Enterprises Inc. will provide replacement parts for only those items purchased within the last 9 months. If this product has not been purchased from our retail affiliates (within 9 months), we are under no obligation to provide parts or replacements merchandise. Parts will not be available for items arriving fully assembled.



Customer Service 1-800-633-5096

service@seidal.com

Southern Enterprises, Inc.

600 Freeport Parkway Suite 200

Coppell, Texas 75019